



Service Manual

Models: LM009CI-100P432-1/ LM009CO-100P432-1
LM012CI-100P432-1/ LM012CO-100P432-1
(Refrigerant R410A)

Thank you for selecting LENNOX air conditioners.

Table of Contents

Part I : Technical Information	1
1. Summary	1
2. Specifications	2
2.1 Specification Sheet.....	2
2.2 Capacity Curve in Different Outdoor Temperature	4
2.3 Cooling Data Sheet in Rated Frequency	4
3. Outline Dimension Diagram	5
3.1 Indoor Unit.....	5
3.2 Outdoor Unit.....	6
4. Refrigerant System Diagram	7
5. Electrical Part	8
5.1 Wiring Diagram.....	8
5.2 PCB Printed Diagram	10
6. Function and Control	11
6.1 Remote Controller Introduction	11
6.2 Brief Description of Modes and Functions.....	15
Part II : Installation and Maintenance	20
7. Notes for Installation and Maintenance	20
8. Installation	22
8.1 Installation Dimension Diagram.....	22
8.2 Installation Parts-Checking	24
8.3 Selection of Installation Location.....	24
8.4 Electric Connection Requirement.....	24
8.5 Installation of Indoor Unit.....	24
8.6 Installation of Outdoor Unit.....	27
8.7 Vacuum Pumping and Leak Detection	28
8.8 Check after Installation and Test Operation	28
9. Maintenance	29
9.1 Error Code.....	29
9.2 Procedure of Troubleshooting	30
9.3 Maintenance Method for Normal Malfunction.....	35

10. Exploded View and Parts List	37
10.1 Indoor Unit.....	37
10.2 Outdoor Unit	39
11. Removal Procedure	43
11.1 Removal Procedure of Indoor Unit	43
11.2 Removal Procedure of Outdoor Unit	48
Appendix:	56
Appendix 1: Reference Sheet of Celsius and Fahrenheit	56
Appendix 2: Configuration of Connection Pipe.....	56
Appendix 3: Pipe Expanding Method	57
Appendix 4: List of Resistance for Temperature Sensor	58

Part I : Technical Information

1. Summary

Indoor Unit:

LM009CI-100P432-1
LM012CI-100P432-1

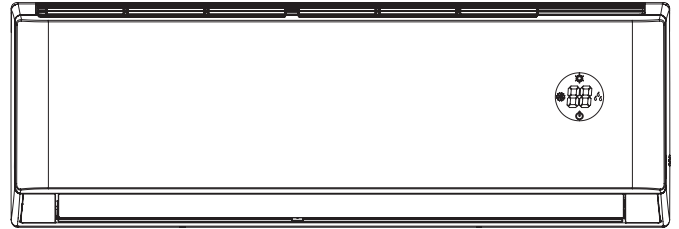

Outdoor Unit:

LM009CO-100P432-1

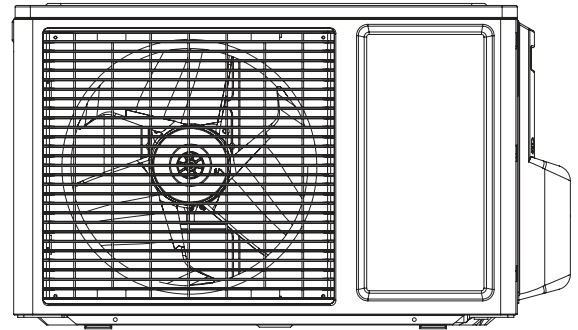

LM012CO-100P432-1

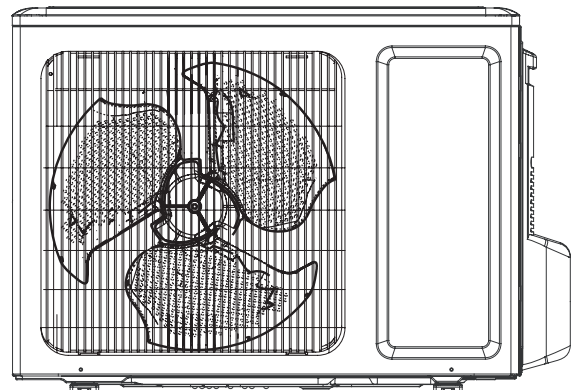

Remote Controller:

YV1FB7



2. Specifications

2.1 Specification Sheet

Model			LM009CI-100P432-1 LM009CO-100P432-1	LM012CI-100P432-1 LM012CO-100P432-1	
Product Code			Y6916 Y6917	Y6918 Y6919	
Power Supply	Rated Voltage	V~	220	220	
	Rated Frequency	Hz	60	60	
	Phases		1	1	
Power Supply Mode			Indoor	Indoor	
Cooling Capacity		Btu/h	9000	12000	
Heating Capacity		W	/	/	
Cooling Power Input		W	900	1200	
Heating Power Input		W	/	/	
Cooling Power Current		A	4.3	5	
Heating Power Current		A	/	/	
Rated Input		W	1060	1400	
Rated Current		A	5.5	8	
Air Flow Volume (SH/H/M/L/SL)		m ³ /h	450/410/340/270/-	550/460/380/300/-	
Dehumidifying Volume		L/h	1	1	
EER		Btu/w.h	10.0	10.0	
COP		W/W	/	/	
SEER		W/W	/	/	
HSPF		W/W	/	/	
Application Area		m ²	10-16	16-24	
Indoor Unit	Model of indoor unit		LM009CI-100P432-1	LM012CI-100P432-1	
	Indoor Unit Product Code		Y6916	Y6918	
	Fan Type		Cross-flow	Cross-flow	
	Diameter Length(DXL)		mm	Φ98X507	Φ98X580
	Fan Motor Cooling Speed (SH/H/M/L/SL)		r/min	1350/1200/1000/800/-	1450/1200/1050/800/-
	Fan Motor Heating Speed (SH/H/M/L/SL)		r/min	/	/
	Output of Fan Motor		W	10	20
	Fan Motor RLA		A	0.18	0
	Fan Motor Capacitor		μF	1	1
	Input of Heater		W	/	/
	Evaporator Form			Aluminum Fin-copper Tube	Aluminum Fin-copper Tube
	Pipe Diameter		mm	Φ5	Φ5
	Row-fin Gap		mm	2-1.5	2-1.4
	Coil Length (LXDXW)		mm	510X22.8X266.7	578X22.8X266.7
	Swing Motor Model			MP24AA	MP24AA
	Output of Swing Motor		W	1.5	1.5
	Fuse		A	3.15	3.15
	Sound Pressure Level (SH/H/M/L/SL)		dB (A)	41/37/32/28/-	43/38/33/28/-
	Sound Power Level (SH/H/M/L/SL)		dB (A)	51/47/42/38/-	53/48/43/38/-
	Dimension (WXHXD)		mm	713X270X195	790X275X200
	Dimension of Carton Box (LXWXH)		mm	773X265X347	850X339X262
	Dimension of Package (LXWXH)		mm	776X268X362	852X355X273
	Net Weight		kg	8.5	9
Gross Weight		kg	10	11	

Outdoor Unit	Model of Outdoor Unit		LM009CO-100P432-1	LM012CO-100P432-1
	Outdoor Unit Product Code		Y6917	Y6919
	Compressor Manufacturer/Trademark		ZHUHAI LANDA COMPRESSOR CO. LTD.	Shanghai Hitachi Electrical Appliances Co.,Ltd
	Compressor Model		QXA-A083rT130	ASG112UN-A6DT
	Compressor Oil		RB68EP or FVC68D or FV50S or equivalent	HAF68D1U
	Compressor Type		Rotary	Rotary
	L.R.A.	A	18	30
	Compressor RLA	A	4	5
	Compressor Power Input	W	844	1090
	Overload Protector		Internal UP3-00	UP3-03/HPA-430
	Throttling Method		Capillary	Capillary
	Operation Temp	°C	16~30	16~30
	Ambient Temp (Cooling)	°C	18~43	18~43
	Ambient Temp (Heating)	°C	/	/
	Condenser Form		Aluminum Fin-copper Tube	Aluminum Fin-copper Tube
	Pipe Diameter	mm	Φ7.94	Φ7
	Rows-fin Gap	mm	1-1.4	1-1.4
	Coil Length (LXDXW)	mm	655X19.05X396	730X495X12.7
	Fan Motor Speed	rpm	950	850
	Output of Fan Motor	W	20	30
	Fan Motor RLA	A	0	0.34
	Fan Motor Capacitor	μF	2	2.5
	Air Flow Volume of Outdoor Unit	m ³ /h	1200	1600
	Fan Type		Axial-flow	Axial-flow
	Fan Diameter	mm	Φ320	Φ394.5
	Defrosting Method		/	/
	Climate Type		T1	T1
	Isolation		I	I
	Moisture Protection		IP24	IP24
	Permissible Excessive Operating Pressure for the Discharge Side	MPa	4.3	4.3
	Permissible Excessive Operating Pressure for the Suction Side	MPa	2.5	2.5
	Sound Pressure Level (H/M/L)	dB (A)	50/-/-	50/-/-
	Sound Power Level (H/M/L)	dB (A)	60/-/-	60/-/-
Dimension (WXHXD)	mm	720X428X310	776X540X320	
Dimension of Carton Box (LXWXH)	mm	765X350X475	820X355X580	
Dimension of Package (LXWXH)	mm	768X353X490	823X358X595	
Net Weight	kg	22.5	27	
Gross Weight	kg	24	29.5	
Refrigerant		R410A	R410A	
Refrigerant Charge	kg	0.52	0.63	
Connection Pipe	Length	m	5	5
	Gas Additional Charge	g/m	15	20
	Outer Diameter Liquid Pipe	mm	Φ6	Φ6
	Outer Diameter Gas Pipe	mm	Φ9.52	Φ12
	Max Distance Height	m	5	10
	Max Distance Length	m	15	20
Note: The connection pipe applies metric diameter.				

The above data is subject to change without notice; please refer to the nameplate of the unit.

2.2 Capacity Curve in Different Outdoor Temperature

Cooling:

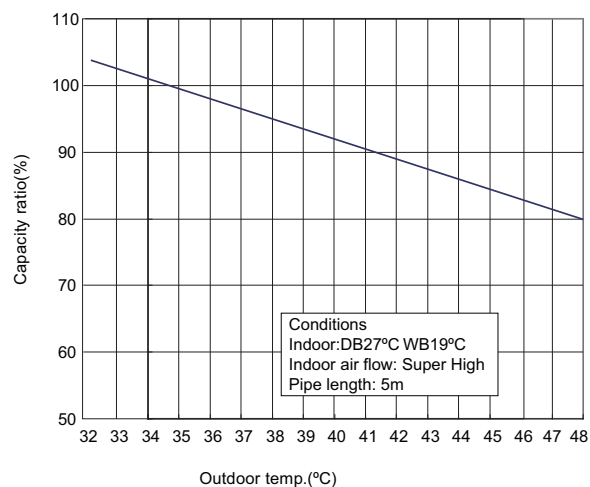

2.3 Cooling Data Sheet in Rated Frequency

Cooling:

Rated cooling condition(°C) (DB/WB)		Model	Pressure of gas pipe connecting indoor and outdoor unit	Inlet and outlet pipe temperature of heat exchanger		Fan speed of indoor unit	Fan speed of outdoor unit
Indoor	Outdoor		P (MPa)	T1 (°C)	T2 (°C)		
27/19	35/24	LM009CI-100P432-1 LM009CO-100P432-1	0.48~0.56	in:9~11 out:11~13	in:75~85 out:37~43	Super High	High
27/19	35/24	LM012CI-100P432-1 LM012CO-100P432-1	0.4~0.6	in:9~11 out:11~13	in:75~85 out:37~43	Super High	High

Instruction:

T1: Inlet and outlet pipe temperature of evaporator

T2: Inlet and outlet pipe temperature of condenser

P: Pressure at the side of big valve

Connection pipe length: 5 m.

3. Outline Dimension Diagram

3.1 Indoor Unit

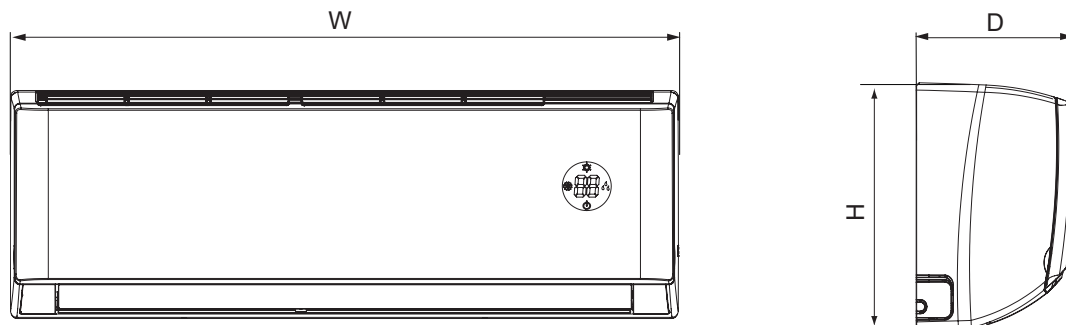

LM009CI-100P432-1

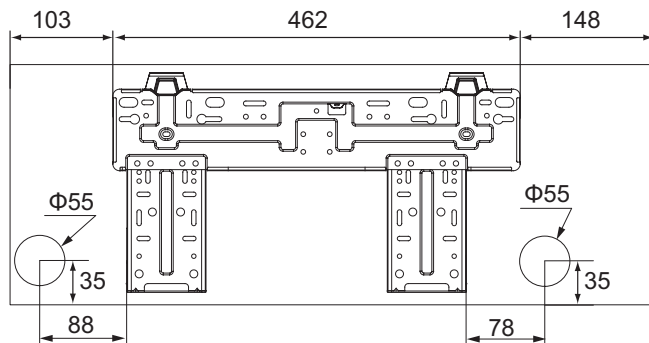

LM012CI-100P432-1

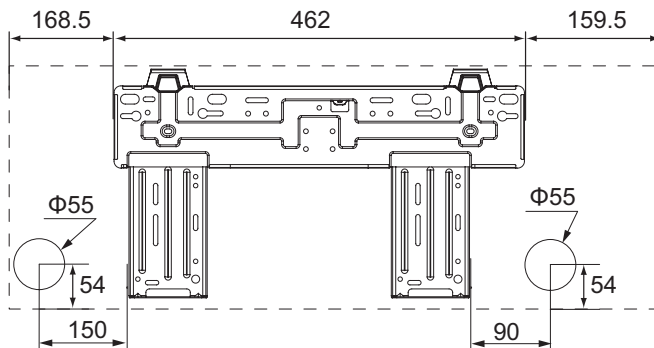

Unit:mm

Model	W	H	D
LM009CI-100P432-1	713	270	195
LM012CI-100P432-1	790	275	200

3.2 Outdoor Unit

LM009CO-100P432-1

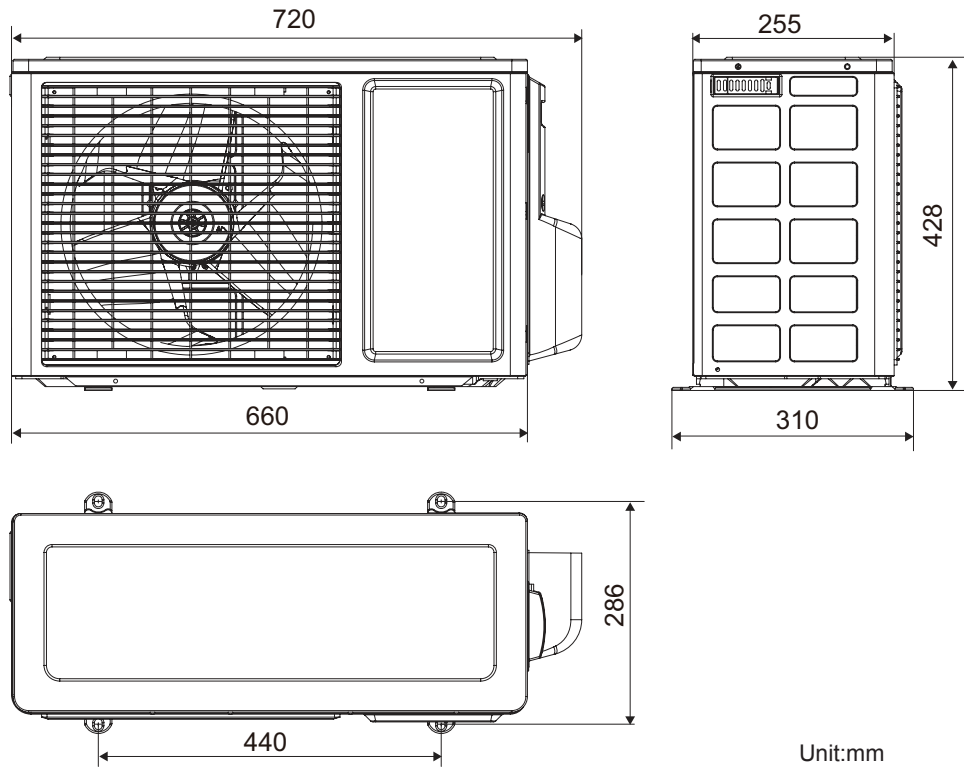

LM012CO-100P432-1

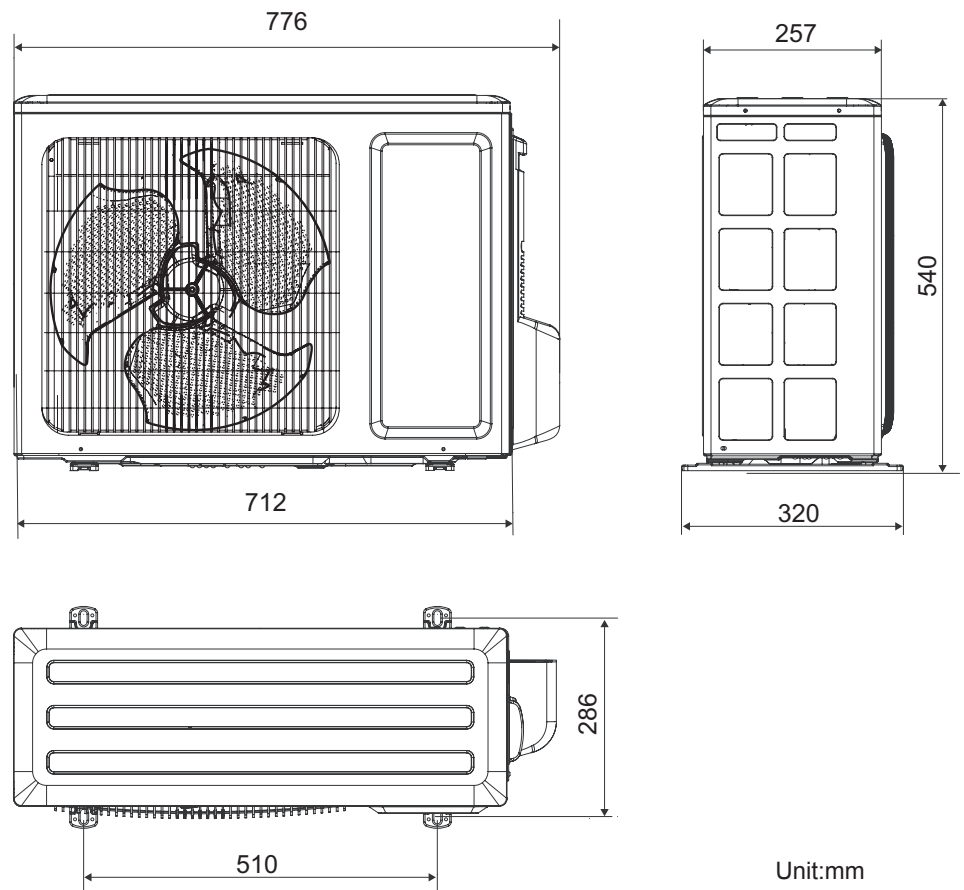

4. Refrigerant System Diagram

Cooling unit

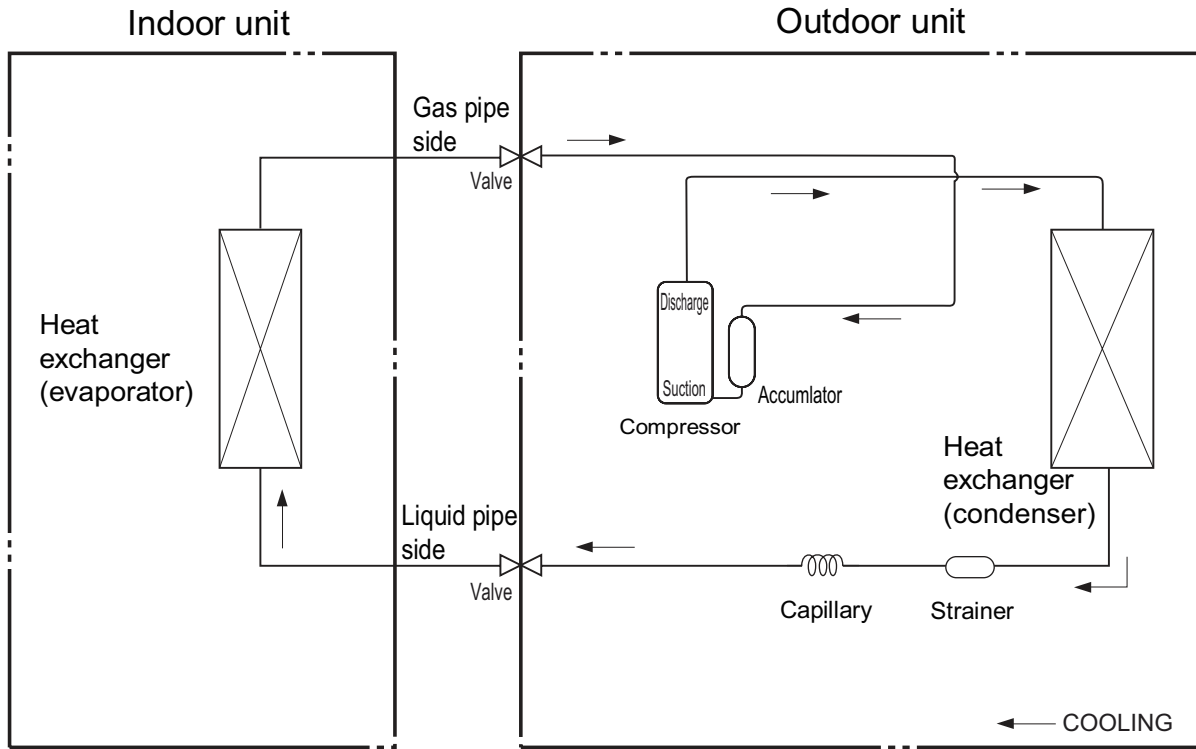

Connection pipe specification:

Liquid pipe: 1/4" (6mm)

Gas pipe: 3/8" (9.52mm)(LM009CI-100P432-1 LM009CO-100P432-1)

Gas pipe: 1/2" (12mm)(LM012CI-100P432-1 LM012CO-100P432-1)

5. Electrical Part

5.1 Wiring Diagram

• Instruction

Symbol	Symbol Color	Symbol	Symbol Color	Symbol	Name
WH	White	GN	Green	CAP	Jumper cap
YE	Yellow	BN	Brown	COMP	Compressor
RD	Red	BU	Blue	⊕	Grounding wire
YEGN	Yellow/Green	BK	Black	/	/

Note: Jumper cap is used to determine fan speed and the swing angle of horizontal lover for this model.

• Indoor Unit

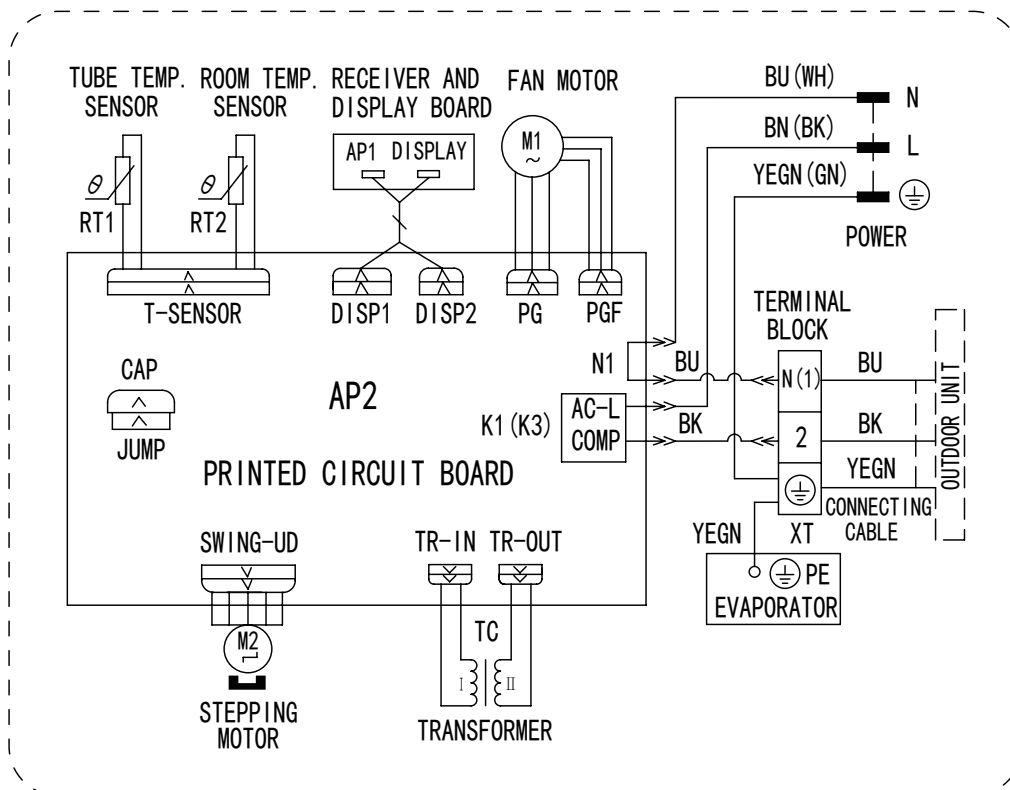

• Outdoor Unit

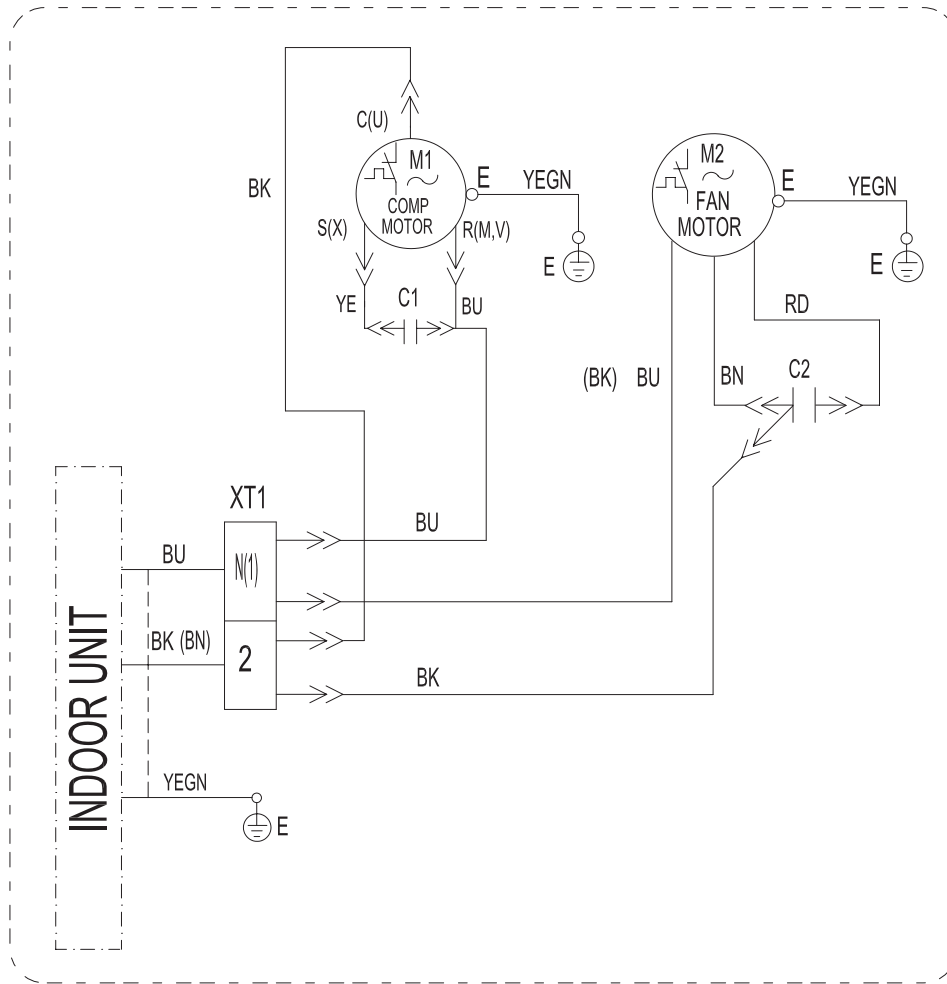

These wiring diagrams are subject to change without notice; please refer to the one supplied with the unit.

5.2 PCB Printed Diagram

• Top view

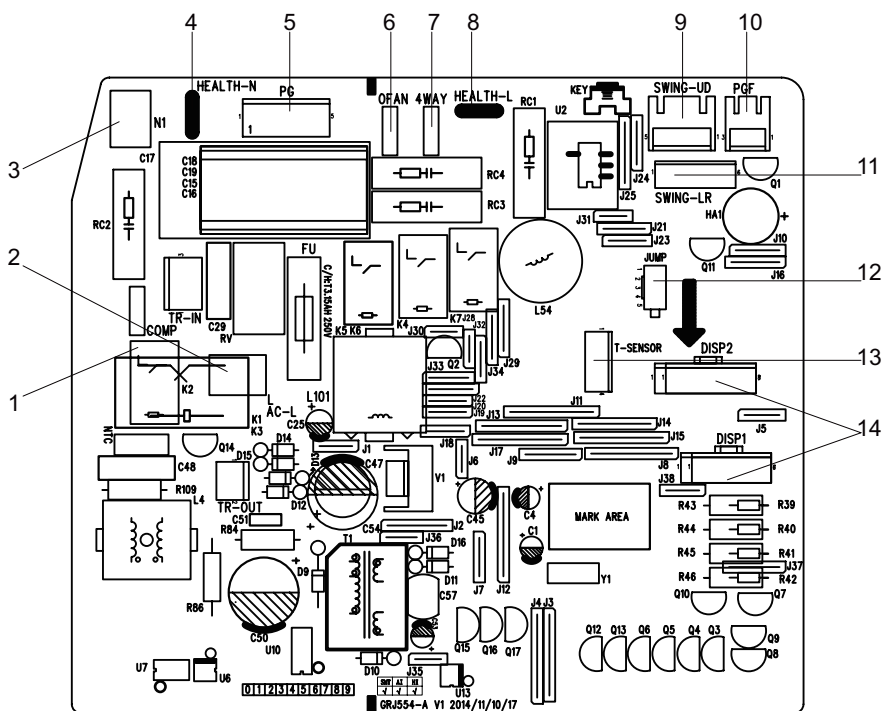

No.	Name
1	Interface of compressor
2	Live wire interface of power cord
3	Neutral wire interface of power cord
4	Neutral wire interface of cold plasma
5	Interface of PG motor
6	Interface of outdoor motor
7	Interface of 4-way valve
8	Live wire interface of cold plasma
9	Interface of up & down feedback
10	Interface of PG motor feedback
11	Interface of left & right swing
12	Jumper cap
13	Interface of temperature sensor
14	Interface of display board

• Bottom view

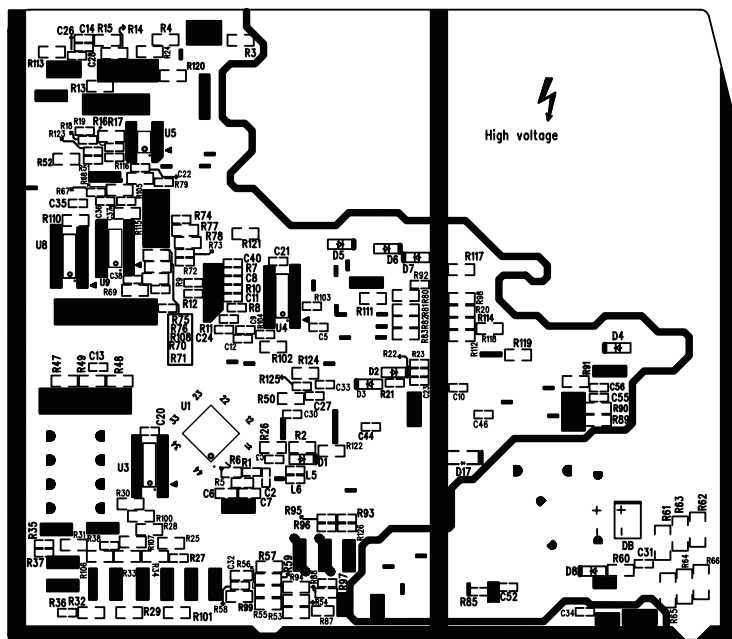

3. MODE button

Each time you press this button, a mode is selected in a sequence that goes from AUTO, COOL, DRY, FAN, and HEAT *, as the following:

AUTO ► COOL ► DRY ► FAN ► HEAT*



After energization, AUTO mode is defaulted. In AUTO mode, the set temperature will not be displayed on the LCD, and the unit will automatically select the suitable operation mode in accordance with the room temperature to make indoor room comfortable.

4. SWING button

Press this button to set up & down swing angle, which circularly changes as below:



This remote controller is universal . If any command , or is sent out, the unit will carry out the command as

indicates the guide louver swings as:

5. ▼ button

Press this button to decrease set temperature. Holding it down above 2 seconds rapidly decreases set temperature. In AUTO mode, set temperature is not adjustable.

6. FAN button

This button is used for setting Fan Speed in the sequence that goes from AUTO, , , to , then back to Auto.



7. TIMER OFF button

Press this button to initiate the auto-off timer. To cancel the auto-timer program, simply press the button again. TIMER OFF setting is the same as TIMER ON.

8. CLOCK button

Press CLOCK button, blinking. Within 5 seconds, pressing ▲ or ▼ button adjusts the present time. Holding down either button above 2 seconds increases or decreases the time by 1 minute every 0.5 second and then by 10 minutes every 0.5 second. During blinking after setting, press CLOCK button again to confirm the setting, and then will be constantly displayed.

9. TIMER ON button

Press this button to initiate the auto-ON timer. To cancel the auto-timer program, simply press this button again. After press of this button, disappears and "ON" blinks. 0 0:00 is displayed for ON timesetting. Within 5 seconds, press ▲ or ▼ button to adjust the time value. Every press of either button changes the time setting by 1 minute. Holding down either button rapidly changes the time setting by 1 minute and then 10 minutes. Within 5 Seconds after setting, press TIMER ON button to confirm.

10. SLEEP button

Press this button to go into the SLEEP operation mode. Press it again to cancel this function. This function is available in COOL, HEAT (Only for models with heating function) to maintain the most comfortable temperature for you.

11. TEMP button

Press this button, you can see indoor set temperature, indoor ambient temperature on indoor unit's display. The setting on remote controller is selected circularly as below:

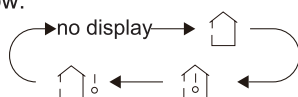

When selecting "" with remote controller or no display, temperature indicator on indoor unit displays set temperature; When selecting "" with remote controller, temperature indicator on indoor unit displays indoor ambient temperature; 3s later or within 3s it receives other remote controller signal that will return to display the setting temperature.

Caution:



- This model hasn't outdoor ambient temperature display function. While remote controller can operate "" and indoor unit displays set temperature.
- It's defaulted to display set temperature when turning on the unit.
- Only for the models with temperature indicator on indoor unit.

12. TURBO button

Press this button to activate / deactivate the Turbo function which enables the unit to reach the preset temperature in the shortest time. In COOL mode, the unit will blow strong cooling air at super high fan speed. In HEAT mode, the unit will blow strong heating air at super high fan speed.

13. X-FAN | button





X-FAN function: In COOL or DRY mode, the icon  is displayed and the indoor fan will continue operation for 2 minutes in order to dry the indoor unit even though you have turned off the unit. After energization, X-FAN OFF is defaulted. X-FAN is not available in AUTO, FAN or HEAT mode.

 function: turn on the display's light and press this button again to turn off the display's light. If the light is turned on,  is displayed. If the light is turned off,  disappears.

14. I FEEL button



Press this button to turn on I FEEL function. The unit automatically adjust temperature according to the sensed temperature. Press this button again to cancel I FEEL function.

15. button

Press this button to achieve the on and off of healthy and scavenging functions in operation status. Press this button for the first time to start scavenging function; LCD displays "". Press the button for the second time to start healthy and scavenging functions simultaneously; LCD displays "" and "". Press this button for the third time to quit healthy and scavenging functions simultaneously. Press the button for the fourth time to start healthy function; LCD display "". Press this button again to repeat the operation above. (This function is applicable to partial of models)

Function introduction for combination buttons

Combination of "▲" and "▼" buttons: About lock

Press "▲" and "▼" buttons simultaneously to lock or unlock the keypad. If the remote controller is locked,  is displayed. In this case, pressing any button,  blinks three times.

Combination of "MODE" and "▼" buttons:

About switch between Fahrenheit and centigrade

At unit OFF, press "MODE" and "▼" buttons simultaneously to switch between °C and °F .

Combination of "TEMP" and "CLOCK" buttons:

About Energy-saving Function

Press "TEMP" and "CLOCK" simultaneously in COOL mode to start energy-saving function. Nixie tube on the remote controller displays "SE". Repeat the operation to quit the function.

Combination of "TEMP" and "CLOCK" buttons:

About 8°C Heating Function

Press "TEMP" and "CLOCK" simultaneously in HEAT mode to start 8°C Heating Function Nixie tube on the remote controller displays "" and a selected temperature of "8°C ".(46 °F if Fahrenheit is adopted). Repeat the operation to quit the function.

About Back-lighting Function

The unit lights for 4s when energizing for the first time, and 3s for later press.

Operation guide

1. After putting through the power, press "ON/OFF" button on remote controller to turn on the air conditioner.
2. Press "MODE" button to select your required mode: AUTO, COOL, DRY, FAN, HEAT.
3. Press "▲" or "▼" button to set your required temperature. (Temperature can't be adjusted under auto mode).
4. Press "FAN" button to set your required fan speed: auto, low, medium and high speed.
5. Press "SWING" button to select fan blowing angle.

Replacement of batteries in remote controller

1. Press the back side of remote controller marked with "", as show in the fig, and then push out the cover of battery box along the arrow direction.
2. Replace two 7# (AAA 1.5V) dry batteries, and make sure the position of "▲" polar and "▼" polar are correct.
3. Reinstall the cover of battery box.

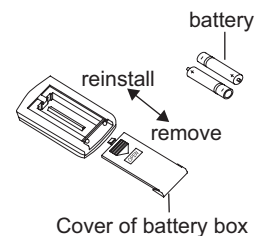

Note:

- During operation, point the remote control signal sender at the receiving window on indoor unit.
- The distance between signal sender and receiving window should be no more than 8m, and there should be no obstacles between them.
- Signal may be interfered easily in the room where there is fluorescent lamp or wireless telephone; remote controller should be close to indoor unit during operation.
- Replace new batteries of the same model when replacement is required.
- When you don't use remote controller for a long time, please take out the batteries.
- If the display on remote controller is fuzzy or there's no display, please replace batteries.

6.2 Brief Description of Modes and Functions

1. Summary

(1) Buzzer

When the controller is energized or receives signal from button (emergency operation switch on air conditioner) or remote controller, the buzzer will give out a beep.

(2) Display

◆ After energization, dual-8 nixie tube and power indicator blink once. Under standby status, the power indicator is in red.

After turning on the unit by remote controller, power indicator is off. The dual-8 nixie tube displays current set temperature.

(Note: No operation indicator, heating indicator, cooling indicator and dry indicator for models with B2 or B4 panels. Therefore, no mode indicator display during operation status.)

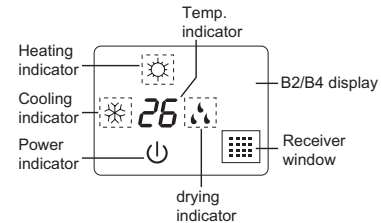

(3) Temperature parameter

- ◆ Indoor set temperature (T_{preset})
- ◆ Indoor ambient temperature (T_{amb})
- ◆ Inner tube temperature of indoor evaporator (T_{tube})

2. Introduction of Basic Mode Function

◆ Once the compressor is energized, there should be a minimum interval of 3 mins between two start-ups.

◆ If the unit is with memory function and is off before power failure, the compressor can be restarted without an interval of 3 mins; if the

◆ unit is on before power failure, the compressor will be restarted with an interval of 3 mins.

Once compressor is started, it won't stop within 6 mins according to the change of room temp.

(1) Auto mode

① Operation condition and process for auto mode

Under auto mode, the system will automatically select operation mode (cooling, heating, and fan) according to indoor ambient temperature. There will be 30s delayed for protection between mode switchover.

◆ When $T_{\text{amb}} \geq 26^\circ\text{C}$, unit will be in cooling mode Ex-factory set temperature is 25°C

◆ Cooling and heating unit: When $T_{\text{amb}} \leq (19^\circ\text{C} + T_{\text{compensation}})$, unit will be in heating mode $T_{\text{preset}} = 20^\circ\text{C}$.

◆ Cooling only unit: When $T_{\text{amb}} \leq 22^\circ\text{C}$, unit will be in fan mode $T_{\text{preset}} = 25^\circ\text{C}$.

◆ For cooling and heating unit under condition that $(19^\circ\text{C} + T_{\text{compensation}}) < T_{\text{amb}} < 26^\circ\text{C}$ (For cooling only unit under condition that $22^\circ\text{C} < T_{\text{amb}} < 26^\circ\text{C}$), when unit is initially turned on in auto mode, it will operate according to auto fan mode. When unit is changed to auto mode from other modes, it will maintain its previous working status (If auto mode is turned on from drying mode, unit will operate according to auto fan mode).

② Protection function is same as that under each mode.

(2) Cooling mode

① Operation condition and process for cooling mode

◆ When $T_{\text{amb}} \geq T_{\text{set}} + 1^\circ\text{C}$, the system operates under cooling mode. In this case, the compressor, the ODU fan motor and the IDU fan motor operates at set speed.

◆ When $T_{\text{amb}} \leq T_{\text{set}} - 1^\circ\text{C}$, the compressor and the ODU fan motor stop, while the IDU fan motor operates at set speed.

◆ When $T_{\text{set}} - 1^\circ\text{C} < T_{\text{amb}} < T_{\text{set}} + 1^\circ\text{C}$, the system will maintain its previous operation status.

In cooling mode, the 4-way valve is de-energized (4-way valve is not available for cooling only unit). Temperature setting range is $16 \sim 30^\circ\text{C}$.

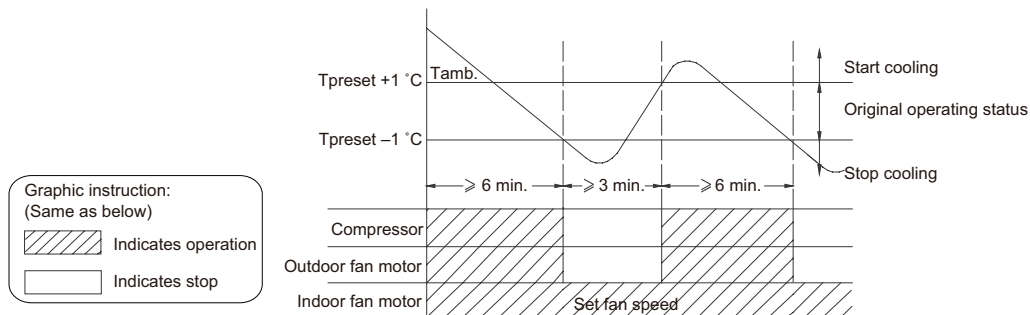

② Protection function

◆ Freeze protection

During operation, when controller detected that $T_{tube} \leq 0^{\circ}\text{C}$ for a consecutive period of time, the system enters into freeze protection. In that case, the compressor and the ODU fan stop operation, while the IDU operates at set fan speed. If freeze protection is released and the compressor has been out of operation for 3 mins, the unit will resume its previous operation status.

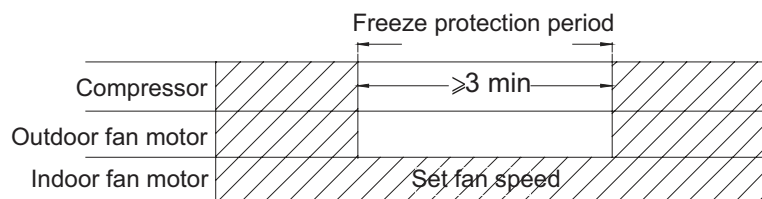
◆ Overcurrent protection (this protection function is not available for those models whose cooling capacity $\leq 12000\text{Btu/h}$)

During operation process, if controller detected that system current exceeds the limit value for 3s consecutively (overcurrent), only the fan operates. About 3 mins later, if overcurrent is released, the system will resume original operation.

If overcurrent protection occurs for 6 times consecutively, and resume operation time won't exceed 6min every time, overcurrent protection information will be displayed. After turning off the unit, display won't be displayed.

If turn on the unit again, the system will be restated up again. Overcurrent protection information will be eliminated.

Please refer to maintenance part for display information and disposal method for details.

◆ Locked protection to IDU fan motor

During operation of IDU fan motor, if controller detected that the rotation speed of IDU fan motor less than 300/min or stop rotation, the motor operates abnormally. In order to prevent damage to motor, controller will protect automatically, the system stops operation and blocked information of IDU fan motor will be displayed. After turning off the unit, display won't be displayed.

If turn on the unit again, the system will be restated up again. Blocked information of IDU fan motor will be eliminated. (For some models, they can only be restated up after re-energized)

Please refer to maintenance part for display information and disposal method for details.

(3) Drying mode

① Operation condition and process for drying mode

◆ When $T_{amb.} > T_{set} + 2^{\circ}\text{C}$, the system starts drying and cooling. In this case, the compressor and the ODU fan motor operate, and the IDU fan motor operates at low speed.

◆ When $T_{set} - 2^{\circ}\text{C} \leq T_{amb.} \leq T_{set} + 2^{\circ}\text{C}$, the system will start drying. In this case, the IDU fan motor operates at low speed; the compressor and the ODU fan motor operate for 6 minutes and stop for 4 minutes in cycle.

◆ When $T_{amb.} < T_{set} - 2^{\circ}\text{C}$, the compressor and the ODU fan motor stop, while the IDU fan motor runs at low speed.

In drying mode, the 4-way valve is de-energized (4-way valve is not available for cooling only unit); Temperature setting range is $16 \sim 30^{\circ}\text{C}$. Fan speed can't be adjusted.

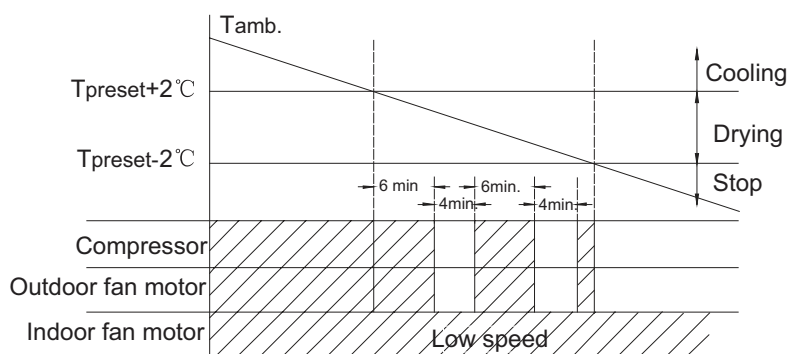

② Protection function

◆ Freeze protection

During drying and cooling operation, when the controller detected that $T_{tube} \leq 0^{\circ}\text{C}$ for a period of time consecutively, the system will enter into freeze protection. In that case, the compressor and the ODU fan motor stops operation, while the IDU fan motor operates at low speed. When freeze protection is release and the compressor has stopped for 3min, the system will resume original operation.

During drying operation, when the controller detected that $T_{tube} \leq 0^{\circ}\text{C}$ for a period of time consecutively, the system enters into freeze protection. In that case, the compressor, the ODU fan motor stops operation, while the IDU fan motor operates at low speed. When freeze protection is release and the compressor has stopped for 4min, the system will resume original operation.

◆ Other protection is same as that under cooling mode.

(4) Fan mode

① Operation condition and process for fan mode

In fan mode, the IDU fan motor operates at set speed, while the compressor and the ODU fan motor stop. 4-way valve is de-energized (4-way valve is not available for cooling only unit). Temperature setting range is 16~30°C .

② Protection function

In fan mode, there are overcurrent protection and blocked protection of IDU fan motor. Please refer to corresponding protection function under cooling mode for details.

(5) Heating mode(no heating mode is not available for cooling only unit)

① Operation conditioner and process for heating mode

◆ When $T_{amb}-T_{compensation} \leq T_{preset}-1^{\circ}C$, unit will operate in heating mode. 4-way valve will be energized while compressor and outdoor fan starts operation at the same time. Indoor fan will start some time later so that air condition won't blow out cold air.

◆ When $T_{amb}-T_{compensation} \geq T_{preset}+1^{\circ}C$, compressor and outdoor fan will stop operation while 4-way valve is still power on. Indoor fan will continue operation for a while at set fan speed to blow out the residual heat so that temperature within the air conditioner won't be too high.

◆ When $T_{preset}-1^{\circ}C < T_{amb}-T_{compensation} < T_{preset}+1^{\circ}C$, system will maintain its previous working status.

In heating mode, 4-way valve is energized. Temperature setting range is 16~30°C .

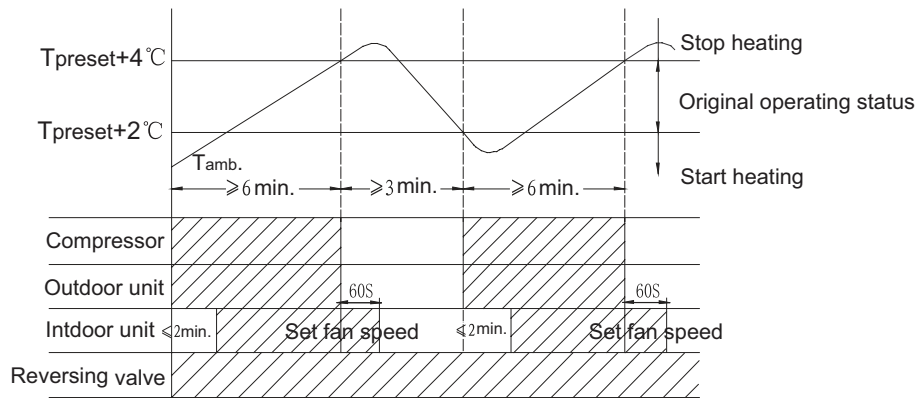

② Defrosting condition and process

For ensuring heating effect, air conditioner will defrost automatically according to defrosting status on outdoor unit. During defrosting, heating icon will be on and off.

③ Protection function

◆ Overheating prevention protection

During operation, when controller detects that $T_{tube} \geq 55^{\circ}C$,the ODU fan motor stops operation; When T_{tube} is resumed normally, the ODU fan motor resumes operation.

◆ Noise silencing protection

When turning off the unit or during mode switchover, the 4-way valve is closed. In order to decrease noise, the 4-way valve will delay 2mins to be closed.

◆ Overcurrent protection (this protection function is not available for those models whose cooling capacity $\leq 12000\text{Btu/h}$)

During operation process, if controller detected that system current exceeds the limit value for 3s consecutively(overcurrent), the system stops operation. About 3mins later, if overcurrent is released, the system will resume original operation. If overcurrent protection occurs for 6 times consecutively, and resume operation time won't exceed 6min every time, overcurrent protection information will be displayed. After turning off the unit, display won't be displayed.

If turn on the unit again, the system will be restated up again. Overcurrent protection information will be eliminated.

Please refer to maintenance part for display information and disposal method for details.

◆ Locked protection to IDU fan motor

During operation of IDU fan motor, if controller detected that the rotation speed of IDU fan motor less than 300/min or stop rotation, the motor operates abnormally. In order to prevent damage to motor, controller will protect automatically, the system stops operation and blocked information of IDU fan motor will be displayed. After turning off the unit, display won't be displayed.

If turn on the unit again, the system will be restated up again. Blocked information of IDU fan motor will be eliminated. (For some models, they can only be restated up after re-energized)

Please refer to maintenance part for display information and disposal method for details.

3. Other Control Function Introduction

(1) Timer function

Controller has general timer function and clock timer function. When you select the remote controller with general timer function, only

the general timer function of controller can be activated; when you select the remote controller with clock timer, only the clock timer function of controller can be activated.

① General timer: The precision of general timer is 0.5hour. 24hours circulated timer can't be set.

◆ Timer ON: Timer ON can be set at unit OFF. If selected ON time is reached, the unit will start to operate according to previous setting status. Time setting range is 0.5~24hr in 30-minute increments.

◆ Timer OFF: Timer OFF can be set at unit ON. If selected OFF time is reached, the unit will stop. Time setting range is 0.5~24hr in 30-minute increments.

② Clock timer: The precision of clock timer is 1minute. 24hours circulated timer can be set.

◆ Timer ON: If timer ON is set during operation of the unit, the unit will continue to operate. If timer ON is set at unit OFF, upon ON time reaches, the unit will start to run according to previous setting status.

◆ Timer OFF: If timer OFF is set at unit OFF, the system will keep standby status. If timer OFF is set at unit ON, upon OFF time reaches, the unit will stop operation.

◆ Timer change:

Although timer has been set, the unit still can be turned on/off by pressing ON/OFF button on the remote controller. You can also reset the timer.

If timer ON and timer OFF are set at the same time during operation of the unit, the unit will keep running at current status till OFF time reaches. Upon ON time reached, the system will be turned on automatically. The unit will operate circularly like that every 24hours.

If timer ON and timer OFF are set at unit OFF status, the system keep OFF status till ON time reaches. Upon OFF time reaches, the system will be turned OFF automatically. The unit will operate circularly like that every 24hours.

(2) Emergency operation switch

After pressing this button, the system will operate according under auto mode and the IDU fan motor operates at auto speed. Swing motor operates when the IDU fan motor operates. Press this button again to turn off the unit.



(3) Sleep function

In this mode, the system will select proper sleep curve to operate according to different set temperature.

① If start up sleep function under cooling or drying mode, the system will increase set temperature automatically within a certain range to operate.

② If start up sleep function under heating mode, the system will decrease set temperature automatically within a certain range to operate.

(4) Turbo function

Turbo function can be set under cooling and heating modes. During operation of turbo function, the system operates at the maximum fan speed.

(5) Dry function

Dry function can be set under cooling and drying modes. During operation of drying function, the fan will stop operation after operating for a period of time when turning off the unit.

(6) Auto fan speed control

Auto fan speed control can be set under cooling, heating and fan mode. During operation of auto fan speed control, the IDU fan motor will adjust the fan speed (high, medium or low speed) according to ambient temperature.

(7) Up&down swing control

① After energization, up & down swing motor will firstly have the horizontal louver rotate anticlockwise to position O to close air outlet. If swing function has not been set after start-up of the unit, horizontal louver will turn clockwise to position D in heating mode, or turn clockwise to level position L in other modes.

② If swing function is set when turning on the unit, the horizontal louver will swing between L and D.

Horizontal louver has 7 swing statuses:

◆ Stay at position L: control by remote controller:

◆ Stay at position A: control by remote controller:

◆ Stay at position B: control by remote controller:

◆ Stay at position C: control by remote controller:

◆ Stay at position D: control by remote controller:

◆ Swing between L and D: control by remote controller:

◆ Stop at any position between L and D (angles between L and D are equiangular) and no display on remote controller.

③ When turning off the unit, horizontal louver will close at position O.

④ Swing action is valid only when set swing command and the IDU fan motor is operating.

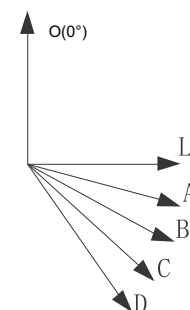

(8) Dual-8 nixie tube display

- ◆ When the air conditioner is turned on for the first time, dual-8 nixie tube defaulted to display current set temperature.
- ◆ When controller receives signal of display set temperature, dual-8 nixie tube displays set temperature. When received remote control signal is switched to indoor ambient temperature display status signal from other display status, dual-8 nixie tube will display indoor ambient temperature for 3-5s, and then turn back to display set temperature. If remote control to set other status, the display keeps the same.
- ◆ When air conditioner has a malfunction, dual-8 nixie tube will show relevant error code.

F1	Indoor ambient temperature sensor is open/short-circuited
F2	Indoor evaporator temperature sensor is open/short-circuited
H6	Blocked protection of IDU fan motor
C5	Malfunction protection of jumper cap
U8	Zero-crossing inspection circuit malfunction of the IDU fan motor
E8	Overload protection

- ◆ When air conditioner is in auto defrosting, heating icon will be on and off.
- ◆ If turn off light button, all display will be turned off.

(9) Memory function

① Power failure when turning on the unit

- ◆ Memory content: ON status, mode, up&down swing, light, set temperature, set fan speed, general timer, Fahrenheit/ Celsius
- ◆ General timer can be memorized. Time of timer is calculated again from energization.
- ◆ Clock timer can't be memorized.

② Power failure when turning off the unit

- ◆ Memory content: OFF status, mode, up&down swing, light, set temperature, set fan speed, general timer, Fahrenheit/ Celsius
- ◆ General timer can be memorized. Time of timer is calculated again from energization.
- ◆ Clock timer can't be memorized.

4. Special Function

(1) Health function (for the model with health function)

During operation of the IDU fan motor, press health button on the remote controller to start health function (If there is not health button on the remote controller, the unit defaults health function ON).

(2) I Feel function (for all models, but it needs the remote controller which can set this function)

When I FEEL command is received, the controller will operate according to the ambient temperature sent by the remote controller (For defrosting and cold air prevention, the unit operates according to the ambient temperature sensed by the air conditioner). The remote controller will regularly send ambient temperature data to the controller. When the data has not been received for a long time, the unit will operate according to the temperature sensed by the air conditioner. If I FEEL function is not set, the ambient temperature will be that sensed by the air conditioner.

Part II : Installation and Maintenance

7. Notes for Installation and Maintenance

Safety Precautions: Important!

Please read the safety precautions carefully before installation and maintenance.

The following contents are very important for installation and maintenance.

Please follow the instructions below.

- The installation or maintenance must accord with the instructions.
- Comply with all national electrical codes and local electrical codes.
- Pay attention to the warnings and cautions in this manual.
- All installation and maintenance shall be performed by distributor or qualified person.
- All electric work must be performed by a licensed technician according to local regulations and the instructions given in this manual.
- Be caution during installation and maintenance. Prohibit incorrect operation to prevent electric shock, casualty and other accidents.



Warnings

Electrical Safety Precautions:

1. Cut off the power supply of air conditioner before checking and maintenance.
2. The air condition must apply specialized circuit and prohibit share the same circuit with other appliances.
3. The air conditioner should be installed in suitable location and ensure the power plug is touchable.
4. Make sure each wiring terminal is connected firmly during installation and maintenance.
5. Have the unit adequately grounded. The grounding wire can't be used for other purposes.
6. Must apply protective accessories such as protective boards, cable-cross loop and wire clip.
7. The live wire, neutral wire and grounding wire of power supply must be corresponding to the live wire, neutral wire and grounding wire of the air conditioner.
8. The power cord and power connection wires can't be pressed by hard objects.
9. If power cord or connection wire is broken, it must be replaced by a qualified person.

10. If the power cord or connection wire is not long enough, please get the specialized power cord or connection wire from the manufacture or distributor. Prohibit prolong the wire by yourself.

11. For the air conditioner without plug, an air switch must be installed in the circuit. The air switch should be all-pole parting and the contact parting distance should be more than 3mm.

12. Make sure all wires and pipes are connected properly and the valves are opened before energizing.

13. Check if there is electric leakage on the unit body. If yes, please eliminate the electric leakage.

14. Replace the fuse with a new one of the same specification if it is burnt down; don't replace it with a cooper wire or conducting wire.

15. If the unit is to be installed in a humid place, the circuit breaker must be installed.

Installation Safety Precautions:

1. Select the installation location according to the requirement of this manual.(See the requirements in installation part)
2. Handle unit transportation with care; the unit should not be carried by only one person if it is more than 20kg.
3. When installing the indoor unit and outdoor unit, a sufficient fixing bolt must be installed; make sure the installation support is firm.
4. Ware safety belt if the height of working is above 2m.
5. Use equipped components or appointed components during installation.
6. Make sure no foreign objects are left in the unit after finishing installation.

Refrigerant Safety Precautions:

1. Avoid contact between refrigerant and fire as it generates poisonous gas; Prohibit prolong the connection pipe by welding.
2. Apply specified refrigerant only. Never have it mixed with any other refrigerant. Never have air remain in the refrigerant line as it may lead to rupture or other hazards.
3. Make sure no refrigerant gas is leaking out when installation is completed.
4. If there is refrigerant leakage, please take sufficient measure to minimize the density of refrigerant.
5. Never touch the refrigerant piping or compressor without wearing glove to avoid scald or frostbite.

Improper installation may lead to fire hazard, explosion, electric shock or injury.

Main Tools for Installation and Maintenance

<p>1. Level meter, measuring tape</p> 	<p>2. Screw driver</p> 	<p>3. Impact drill, drill head, electric drill</p> 
<p>4. Electroprobe</p> 	<p>5. Universal meter</p> 	<p>6. Torque wrench, open-end wrench, inner hexagon spanner</p> 
<p>7. Electronic leakage detector</p> 	<p>8. Vacuum pump</p> 	<p>9. Pressure meter</p> 
<p>10. Pipe pliers, pipe cutter</p> 	<p>11. Pipe expander, pipe bender</p> 	<p>12. Soldering appliance, refrigerant container</p> 

8. Installation

8.1 Installation Dimension Diagram

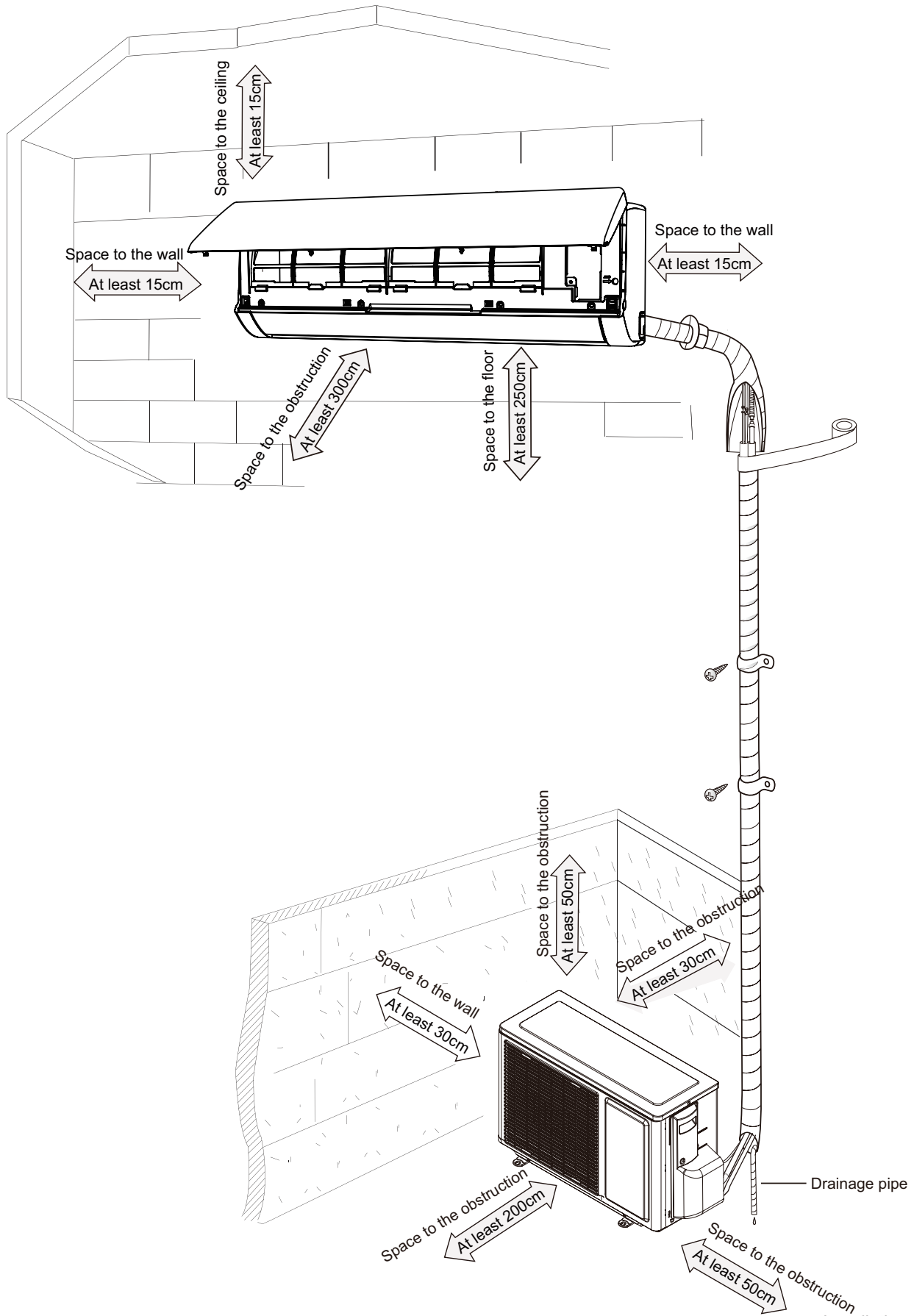

Installation procedures

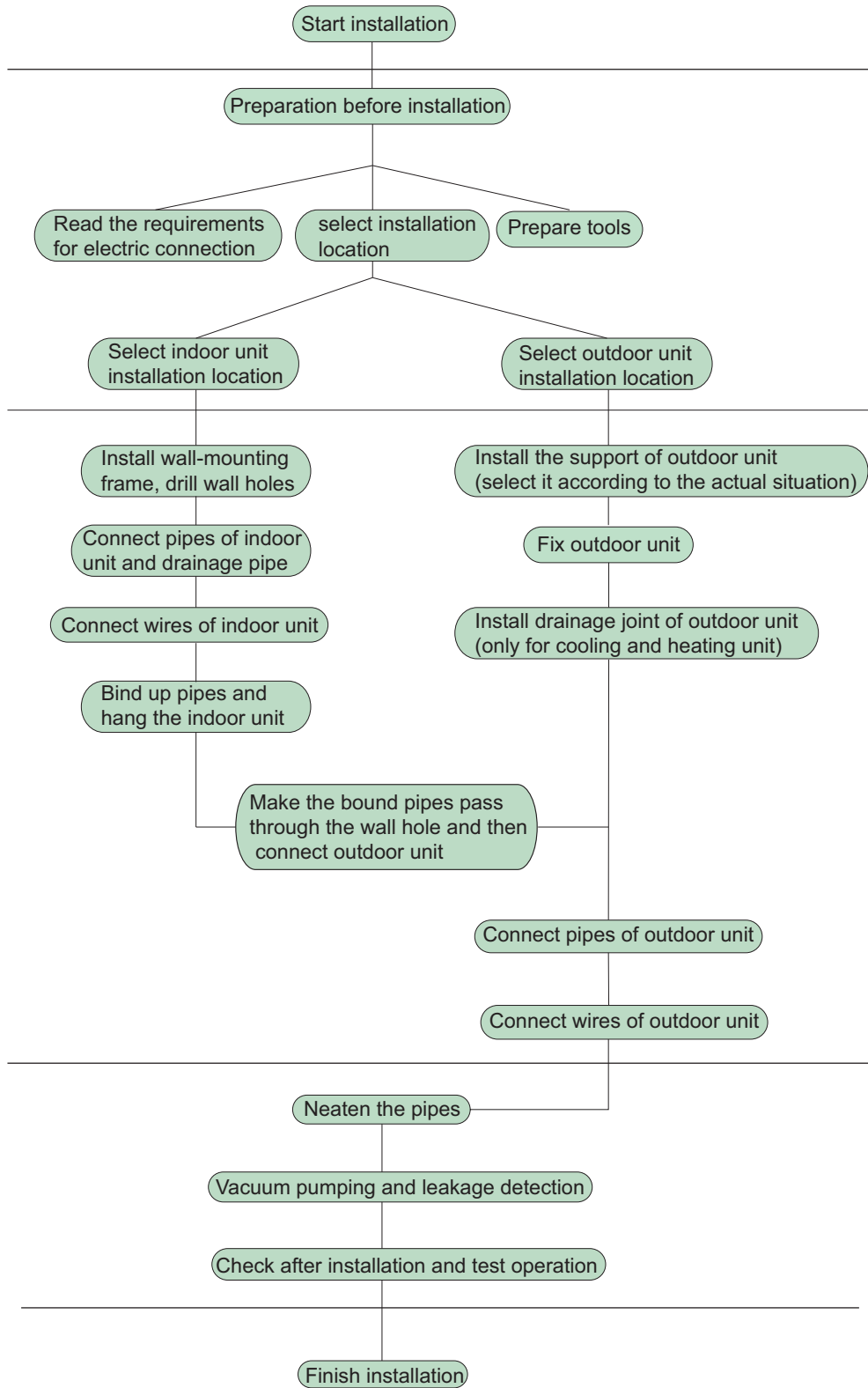

Note: this flow is only for reference; please find the more detailed installation steps in this section.

8.2 Installation Parts-Checking

No.	Name	No.	Name
1	Indoor unit	8	Sealing gum
2	Outdoor unit	9	Wrapping tape
3	Connection pipe	10	Support of outdoor unit
4	Drainage pipe	11	Fixing screw
5	Wall-mounting frame	12	Drainage plug(cooling and heating unit)
6	Connecting cable(power cord)	13	Owner's manual, remote controller
7	Wall pipe		

⚠ Note:

1. Please contact the local agent for installation.
2. Don't use unqualified power cord.

8.3 Selection of Installation Location

1. Basic Requirement:

Installing the unit in the following places may cause malfunction. If it is unavoidable, please consult the local dealer:

- (1) The place with strong heat sources, vapors, flammable or explosive gas, or volatile objects spread in the air.
- (2) The place with high-frequency devices (such as welding machine, medical equipment).
- (3) The place near coast area.
- (4) The place with oil or fumes in the air.
- (5) The place with sulfured gas.
- (6) Other places with special circumstances.
- (7) The appliance shall not be installed in the laundry.

2. Indoor Unit:

- (1) There should be no obstruction near air inlet and air outlet.
- (2) Select a location where the condensation water can be dispersed easily and won't affect other people.
- (3) Select a location which is convenient to connect the outdoor unit and near the power socket.
- (4) Select a location which is out of reach for children.
- (5) The location should be able to withstand the weight of indoor unit and won't increase noise and vibration.
- (6) The appliance must be installed 2.5m above floor.
- (7) Don't install the indoor unit right above the electric appliance.
- (8) Please try your best to keep way from fluorescent lamp.

3. Outdoor Unit:

- (1) Select a location where the noise and outflow air emitted by the outdoor unit will not affect neighborhood.
- (2) The location should be well ventilated and dry, in which the outdoor unit won't be exposed directly to sunlight or strong wind.
- (3) The location should be able to withstand the weight of outdoor unit.
- (4) Make sure that the installation follows the requirement of installation dimension diagram.
- (5) Select a location which is out of reach for children and far away from animals or plants. If it is unavoidable, please add fence for safety purpose.

8.4 Electric Connection Requirement

1. Safety Precaution

- (1) Must follow the electric safety regulations when installing the unit.
- (2) According to the local safety regulations, use qualified power supply circuit and air switch.
- (3) Make sure the power supply matches with the requirement of air conditioner. Unstable power supply or incorrect wiring may result in electric shock, fire hazard or malfunction. Please install proper power supply cables before using the air conditioner.

Air-conditioner	Air switch capacity
LM009CI-100P432-1 LM009CO-100P432-1	10A
LM012CI-100P432-1 LM012CO-100P432-1	16A

- (4) Properly connect the live wire, neutral wire and grounding wire of power socket.
- (5) Be sure to cut off the power supply before proceeding any work related to electricity and safety.
- (6) Do not put through the power before finishing installation.
- (7) For appliances with type Y attachment, the instructions shall contain the substance of the following. If the supply cord is damaged, it must be replaced by the manufacturer, its service agent or similarly qualified persons in order to avoid a hazard.
- (8) The temperature of refrigerant circuit will be high, please keep the interconnection cable away from the copper tube.
- (9) The appliance shall be installed in accordance with national wiring regulations.

2. Grounding Requirement:

- (1) The air conditioner is first class electric appliance. It must be properly grounded with specialized grounding device by a professional. Please make sure it is always grounded effectively, otherwise it may cause electric shock.
- (2) The yellow-green wire in air conditioner is grounding wire, which can't be used for other purposes.
- (3) The grounding resistance should comply with national electric safety regulations.
- (4) The appliance must be positioned so that the plug is accessible.
- (5) An all-pole disconnection switch having a contact separation of at least 3mm in all poles should be connected in fixed wiring.
- (6) Including an air switch with suitable capacity, please note the following table. Air switch should be included magnet buckle and heating buckle function, it can protect the circuit-short and overload. (Caution: please do not use the fuse only for protect the circuit)

8.5 Installation of Indoor Unit

1. Choosing Installation location

Recommend the installation location to the client and then confirm it with the client.

2. Install Wall-mounting Frame

- (1) Hang the wall-mounting frame on the wall; adjust it in horizontal position with the level meter and then point out the screw fixing holes on the wall.
- (2) Drill the screw fixing holes on the wall with impact drill (the specification of drill head should be the same as the plastic expansion particle) and then fill the plastic expansion particles

in the holes.

(3) Fix the wall-mounting frame on the wall with tapping screws (ST4.2X25TA) and then check if the frame is firmly installed by pulling the frame. If the plastic expansion particle is loose, please drill another fixing hole nearby.

3. Install Wall-mounting Frame

(1) Choose the position of piping hole according to the direction of outlet pipe. The position of piping hole should be a little lower than the wall-mounted frame.(As show in Fig.1)

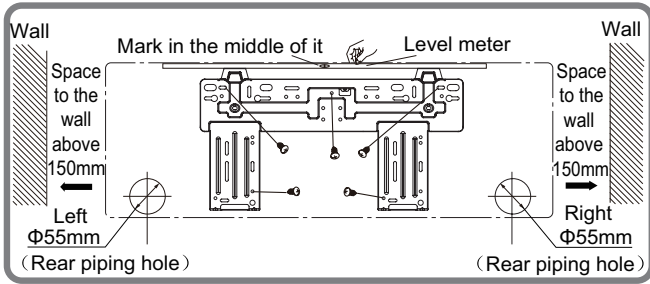

Fig.1

(2) Open a piping hole with the diameter of Φ55mm on the selected outlet pipe position. In order to drain smoothly, slant the piping hole on the wall slightly downward to the outdoor side with the gradient of 5-10°. (As show in Fig.2)

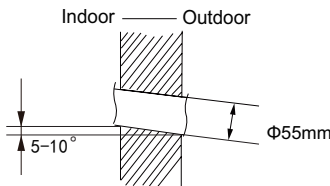

Fig.2

⚠ Note:

- (1) Pay attention to dust prevention and take relevant safety measures when opening the hole.
- (2) The plastic expansion particles are not provided and should be bought locally.

4. Outlet Pipe

(1) The pipe can be led out in the direction of right, rear right, left or rear left.(As show in Fig.3)

(2) When selecting leading out the pipe from left or right, please cut off the corresponding hole on the bottom case.(As show in Fig.4)

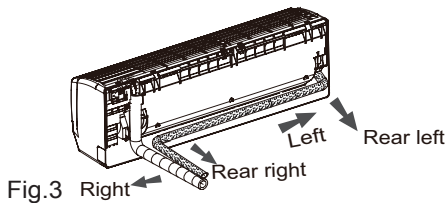

Fig.3

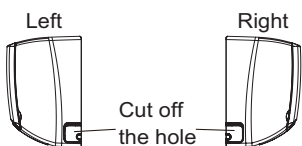

Fig.4

5. Connect the Pipe of Indoor Unit

(1) Aim the pipe joint at the corresponding bellmouth.(As show in Fig.5)

(2) Pretightening the union nut with hand.

(3) Adjust the torque force by referring to the following sheet. Place the open-end wrench on the pipe joint and place the torque wrench on the union nut. Tighten the union nut with torque wrench.(As show in Fig.6)

(4) Wrap the indoor pipe and joint of connection pipe with insulating pipe, and then wrap it with tape.(As show in Fig.7)

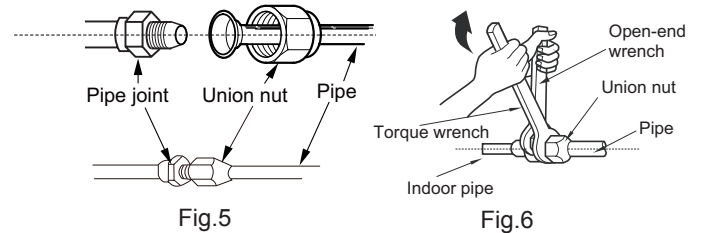
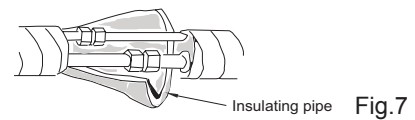

Fig.5

Fig.6



Insulating pipe Fig.7

Refer to the following table for wrench moment of force:

Hex nut diameter(mm)	Tightening torque(N·m)
Φ6	15~20
Φ9.52	30~40
Φ12	45~55
Φ16	60~65
Φ19	70~75

6. Install Drain Hose

(1) Connect the drain hose to the outlet pipe of indoor unit.(As show in Fig.8)

(2) Bind the joint with tape.(As show in Fig.9)

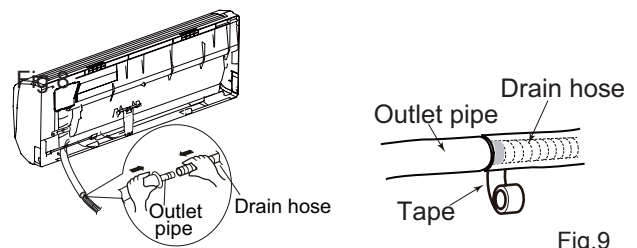

Fig.9

⚠ Note:

- (1) Add insulating pipe in the indoor drain hose in order to prevent condensation.
- (2) The plastic expansion particles are not provided. (As show in Fig.10)

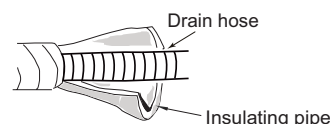

Fig.10

7. Connect Wire of Indoor Unit

(1) Open the panel, remove the screw on the wiring cover and then take down the cover.(As show in Fig.11)

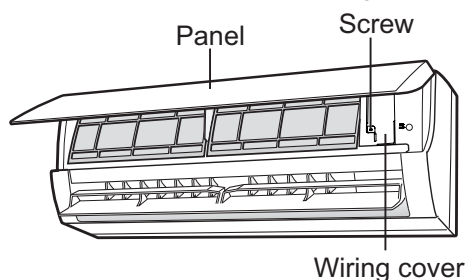

Fig.11

(2) Make the power connection wire go through the cable-cross hole at the back of indoor unit and then pull it out from the front side.(As show in Fig.12)

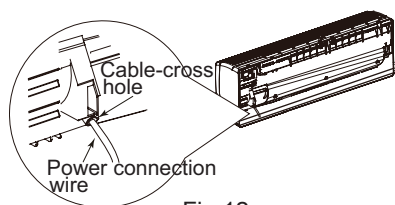

Fig.12

(3) Remove the wire clip; connect the power connection wire and signal control wire (only for cooling and heating unit) to the wiring terminal according to the color; tighten the screw and then fix them with wire clip.(As show in Fig.13)

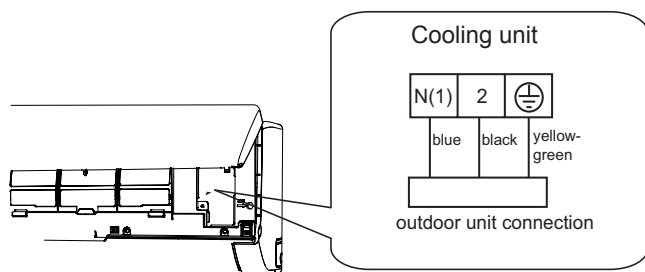

Fig.13

(4) Put wiring cover back and then tighten the screw.
(5) Close the panel.

⚠ Note:

- (1) All wires of indoor unit and outdoor unit should be connected by a professional.
- (2) If the length of power connection wire is insufficient, please contact the supplier for a new one. Avoid extending the wire by yourself.
- (3) For the air conditioner with plug, the plug should be reachable after finishing installation.
- (4) For the air conditioner without plug, an air switch must be installed in the line. The air switch should be all-pole parting and the contact parting distance should be more than 3mm.

8. Bind up Pipe

- (1) Bind up the connection pipe, power cord and drain hose with the band.(As show in Fig.14)
- (2) Reserve a certain length of drain hose and power cord for installation when binding them. When binding to a certain degree, separate the indoor power and then separate the drain hose.(As show in Fig.15)
- (3) Bind them evenly.
- (4) The liquid pipe and gas pipe should be bound separately at the end.

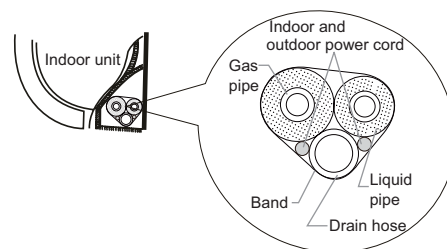

Fig.14

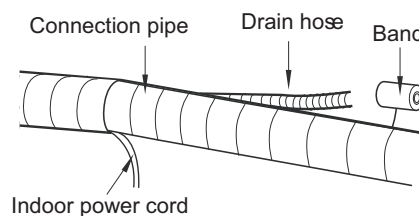

Fig.15

⚠ Note:

- (1) The power cord and control wire can't be crossed or winding.
- (2) The drain hose should be bound at the bottom.

9. Hang the Indoor Unit

- (1) Put the bound pipes in the wall pipe and then make them pass through the wall hole.
- (2) Hang the indoor unit on the wall-mounting frame.
- (3) Stuff the gap between pipes and wall hole with sealing gum.
- (4) Fix the wall pipe.(As show in Fig.16)
- (5) Check if the indoor unit is installed firmly and closed to the wall.(As show in Fig.17)

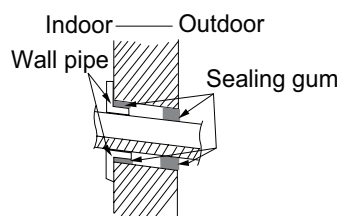
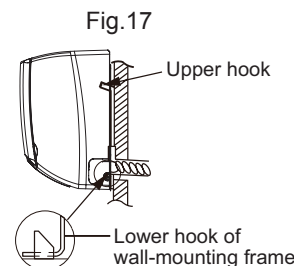

Fig.16



⚠ Note:

Do not bend the drain hose too excessively in order to prevent blocking.

8.6 Installation of Outdoor Unit

1. Fix the Support of Outdoor Unit(Select it according to the actual installation situation)

- (1) Select installation location according to the house structure.
- (2) Fix the support of outdoor unit on the selected location with expansion screws.

⚠ Note:

- (1) Take sufficient protective measures when installing the outdoor unit.
- (2) Make sure the support can withstand at least four times the unit weight.
- (3) The outdoor unit should be installed at least 3cm above the floor in order to install drain joint.(As show in Fig.18)
- (4) For the unit with cooling capacity of 2300W~5000W, 6 expansion screws are needed; for the unit with cooling capacity of 6000W~8000W, 8 expansion screws are needed; for the unit with cooling capacity of 10000W~16000W, 10 expansion screws are needed.

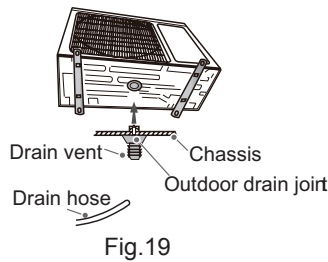
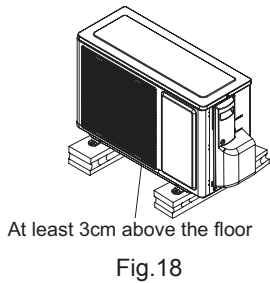

2. Install Drain Joint(Only for cooling and heating unit)

- (1) Connect the outdoor drain joint into the hole on the chassis.
 - (2) Connect the drain hose into the drain vent.
- (As show in Fig.19)

3. Fix Outdoor Unit

- (1) Place the outdoor unit on the support.
- (2) Fix the foot holes of outdoor unit with bolts. (As show in Fig.20)

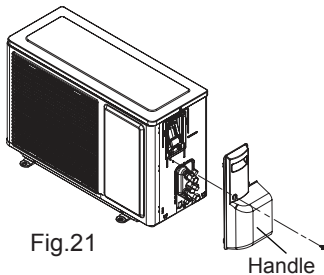
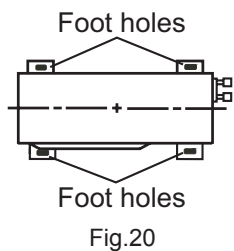

4. Connect Indoor and Outdoor Pipes

- (1) Remove the screw on the right handle of outdoor unit and then remove the handle.(As show in Fig.21)
- (2) Remove the screw cap of valve and aim the pipe joint at the bellmouth of pipe.(As show in Fig.22)

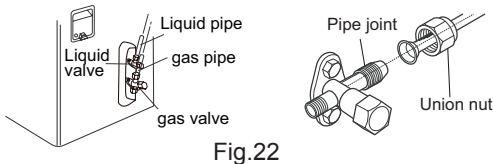

- (3) Pretightening the union nut with hand.
- (4) Tighten the union nut with torque wrench .

Refer to the following table for wrench moment of force:

Hex nut diameter(mm)	Tightening torque(N·m)
Φ6	15~20
Φ9.52	30~40
Φ12	45~55
Φ16	60~65
Φ19	70~75

5. Connect Outdoor Electric Wire

- (1) Remove the wire clip; connect the power connection wire and signal control wire(only for cooling and heating unit) to the wiring terminal according to the color; fix them with screws.(As show in Fig.23)

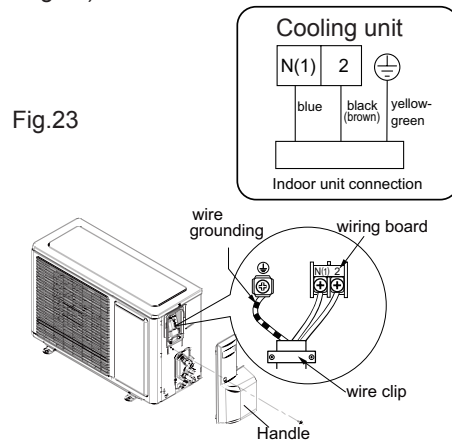

Note: the wiring board is for reference only, please refer to the actual one.

- (2) Fix the power connection wire and signal control wire(only for cooling and heating unit) with wire clip.

⚠ Note:

- (1) After tightening the screw, pull the power cord slightly to check if it is firm.
- (2) Never cut the power connection wire to prolong or shorten the distance.

6. Neaten the Pipes

- (1) The pipes should be placed along the wall, bent reasonably and hidden possibly. Min. semidiameter of bending the pipe is 10cm.
- (2) If the outdoor unit is higher than the wall hole, you must set a U-shaped curve in the pipe before pipe goes into the room, in order to prevent rain from getting into the room.(As show in Fig.24)

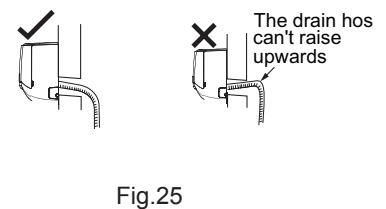
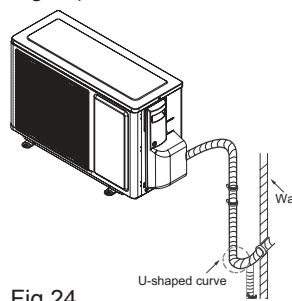

⚠ Note:

- (1) The through-wall height of drain hose shouldn't be higher than the outlet pipe hole of indoor unit. (As show in Fig.25)
- (2) Slant the drain hose slightly downwards. The drain hose can't be curved, raised and fluctuant, etc. (As show in Fig.26)
- (3) The water outlet can't be placed in water in order to drain smoothly. (As show in Fig.27)

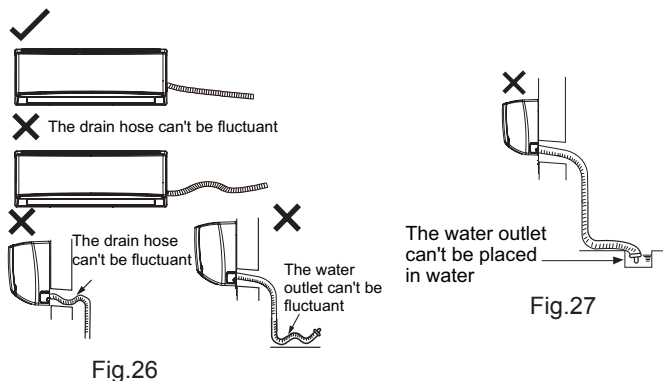

8.7 Vacuum Pumping and Leak Detection

1. Use Vacuum Pump

- (1) Remove the valve caps on the liquid valve and gas valve and the nut of refrigerant charging vent.
- (2) Connect the charging hose of piezometer to the refrigerant charging vent of gas valve and then connect the other charging hose to the vacuum pump.
- (3) Open the piezometer completely and operate for 10-15min to check if the pressure of piezometer remains in -0.1MPa.
- (4) Close the vacuum pump and maintain this status for 1-2min to check if the pressure of piezometer remains in -0.1MPa. If the pressure decreases, there may be leakage.
- (5) Remove the piezometer, open the valve core of liquid valve and gas valve completely with inner hexagon spanner.
- (6) Tighten the screw caps of valves and refrigerant charging vent. (As show in Fig.28)

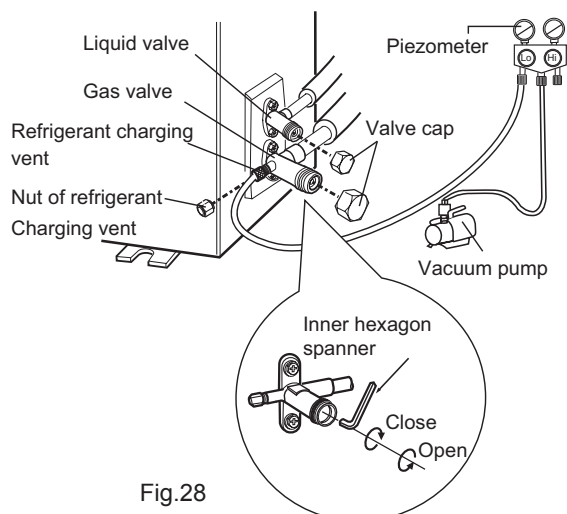

2. Leakage Detection

- (1) With leakage detector: Check if there is leakage with leakage detector.
- (2) With soap water: If leakage detector is not available, please use soap water for leakage detection. Apply soap water at the suspected position and keep the soap water for more than 3min. If there are air bubbles coming out of this position, there's a leakage.

8.8 Check after Installation and Test Operation

1. Check after Installation

Check according to the following requirement after finishing installation.

NO.	Items to be checked	Possible malfunction
1	Has the unit been installed firmly?	The unit may drop, shake or emit noise.
2	Have you done the refrigerant leakage test?	It may cause insufficient cooling (heating) capacity.
3	Is heat insulation of pipeline sufficient?	It may cause condensation and water dripping.
4	Is water drained well?	It may cause condensation and water dripping.
5	Is the voltage of power supply according to the voltage marked on the nameplate?	It may cause malfunction or damage the parts.
6	Is electric wiring and pipeline installed correctly?	It may cause malfunction or damage the parts.
7	Is the unit grounded securely?	It may cause electric leakage.
8	Does the power cord follow the specification?	It may cause malfunction or damage the parts.
9	Is there any obstruction in air inlet and air outlet?	It may cause insufficient cooling (heating).
10	The dust and sundries caused during installation are removed?	It may cause malfunction or damaging the parts.
11	The gas valve and liquid valve of connection pipe are open completely?	It may cause insufficient cooling (heating) capacity.

2. Test Operation

- (1) Preparation of test operation
 - The client approves the air conditioner installation.
 - Specify the important notes for air conditioner to the client.
- (2) Method of test operation
 - Put through the power, press ON/OFF button on the remote controller to start operation.
 - Press MODE button to select AUTO, COOL, DRY, FAN and HEAT to check whether the operation is normal or not.
 - If the ambient temperature is lower than 16°C, the air conditioner can't start cooling.

9. Maintenance

9.1 Error Code

No.	Malfunction Name	Display Method of Indoor Unit (Error Code)	A/C Status	Possible Causes(For specific maintenance method, please refer to the following procedure of troubleshooting)
1	Indoor ambient temperature sensor is open/short-circuited	F1	The unit will stop operation as it reaches the temperature point. During cooling and drying operation, except IDU fan motor operates, other loads stop operation; During heating operation, the system stops operation.	<ol style="list-style-type: none"> 1.The wiring terminal between indoor ambient temperature sensor and main board is loosened or poorly contacted; 2.There's short circuit due to trip-over of the parts on controller; 3.Indoor ambient temperature sensor is damaged (Please check it by referring to the resistance table for temperature sensor) 4. Main board is broken.
2	Indoor evaporator temperature sensor is open/short-circuited	F2	The unit will stop operation as it reaches the temperature point. During cooling and drying operation, except IDU fan operates, other loads stop operation; During heating operation, the complete unit stops operation.	<ol style="list-style-type: none"> 1.The wiring terminal between indoor evaporator temperature sensor and main board is loosened or poorly contacted; 2.There's short circuit due to the trip-over of the parts on controller; 3.Indoor evaporator temperature sensor is damaged (Please check it by referring to the resistance table for temperature sensor) 4. Main board is broken.
3	Blocked protection of IDU fan motor	H6	IDU fan, ODU fan, compressor and electric heat tube stop operation. Horizontal louver stops at the current position.	<ol style="list-style-type: none"> 1.The feedback terminal of PG motor is not connected tightly. 2.The control terminal of PG motor is not connected tightly. 3.Fan blade rotates unsmoothly. 4.Malfunction of motor 5.Main board is broken.
4	Malfunction protection of jumper cap	C5	Operation of remote controller or control panel is available, but the unit won't act.	<ol style="list-style-type: none"> 1.There's not jumper cap on the main board. 2.Jumper cap is not inserted properly and tightly. 3.Jumper cap is damaged. 4.Controller is damaged.
5	Overload malfunction	E8	The entire unit stops.	<ol style="list-style-type: none"> 1.Indoor and outdoor heat exchanger is too dirty? Or air inlet/outlet is blocked? 2.Fan motor is not working. Abnormal fan speed; fan speed is too low or the fan doesn't run. 3.Compressor operates normally or not? Is there any abnormal noise or oil leak? Casing is too hot? 4.System is blocked inside? (Dirt blockage? Ice blockage? Oil blockage? Y-valve is not fully open?) 5.Main board temperature sensor detects wrongly.
6	Zero-crossing inspection circuit malfunction of the IDU fan motor	U8	Operation of remote controller or control panel is available, but the unit won't act.	<ol style="list-style-type: none"> 1.Quick de-energization and energization. Wrong judgement by the controller because the electric-discharging of capacitor is slow. 2.Zero-crossing inspection circuit of main board for controller is abnormal.

9.2 Procedure of Troubleshooting

1. Malfunction of Temperature Sensor F1, F2

Main detection points:

- Is the wiring terminal between the temperature sensor and the controller loosened or poorly contacted?
- Is there short circuit due to trip-over of the parts?
- Is the temperature sensor broken?
- Is mainboard broken?

Malfunction diagnosis process:

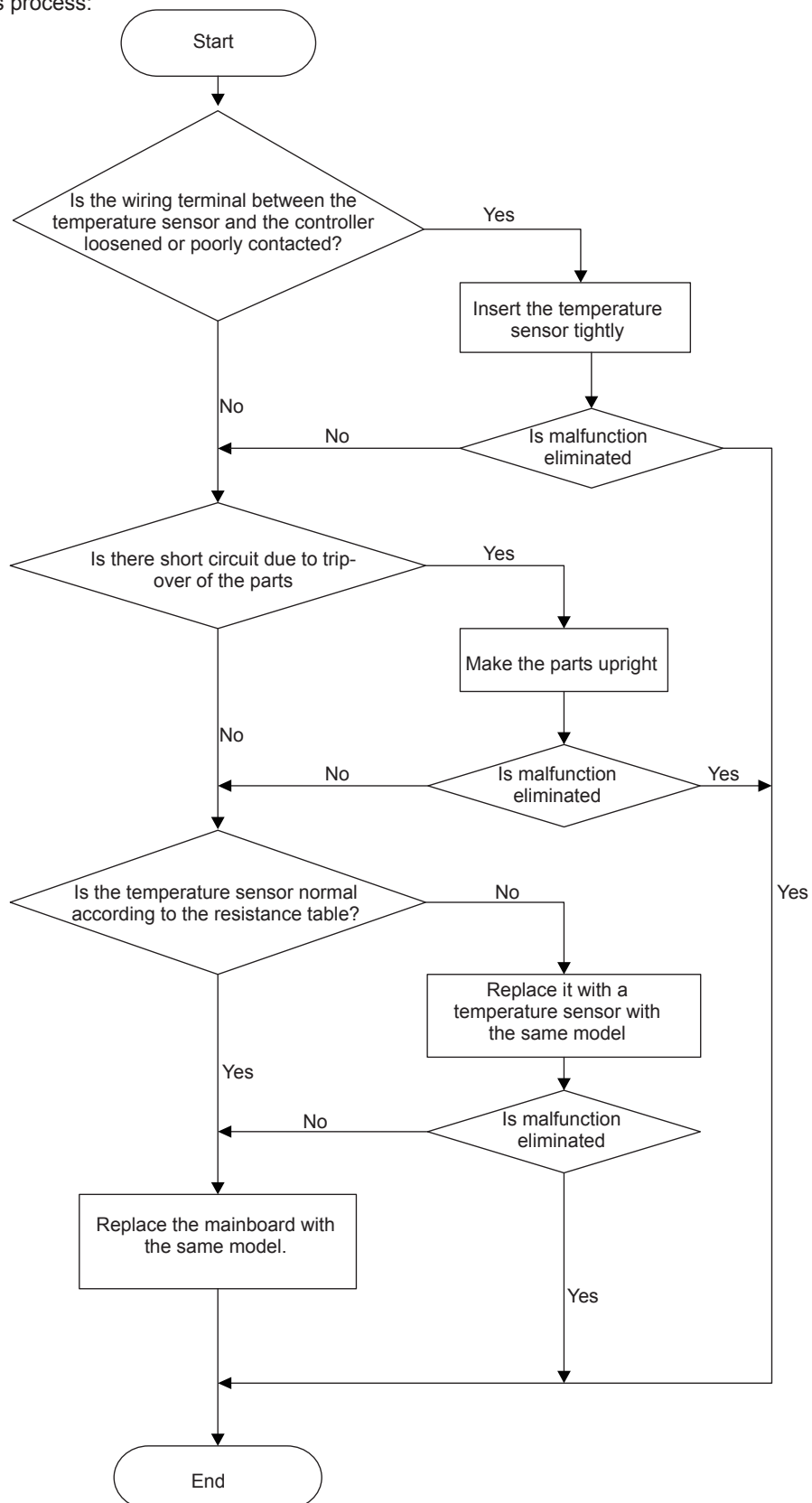

2. Malfunction of Blocked Protection of IDU Fan Motor H6

Main detection points:

- Smoothly Is the control terminal of PG motor connected tightly?
- Smoothly Is the feedback interface of PG motor connected tightly?
- The fan motor can't operate?
- The motor is broken?
- Detection circuit of the mainboard is defined abnormal?

Malfunction diagnosis process:

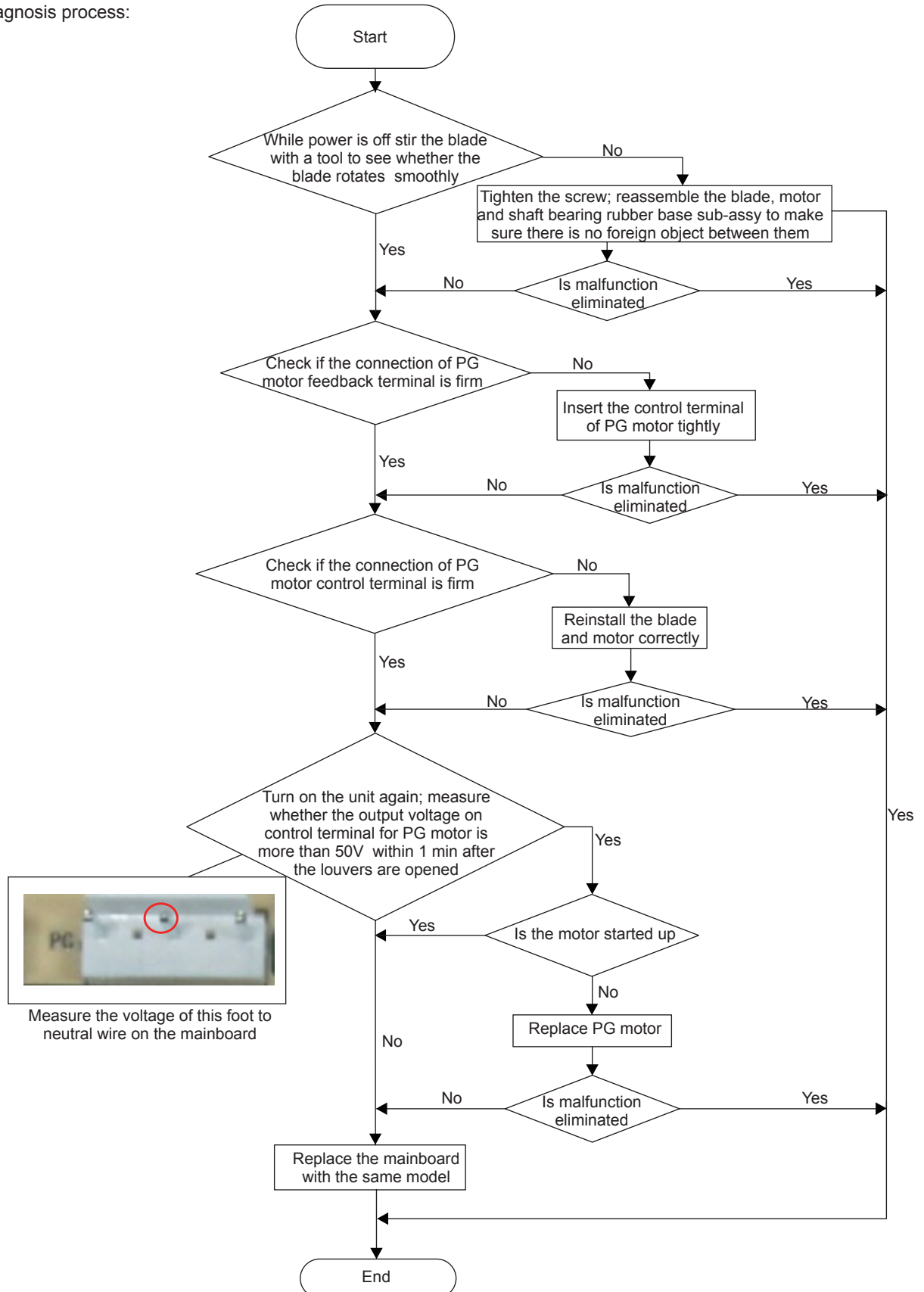

3. Malfunction of Protection of Jumper Cap C5

Main detection points:

- Is there jumper cap on the mainboard?
- Is the jumper cap inserted correctly and tightly?
- The jumper is broken?
- The motor is broken?
- Detection circuit of the mainboard is defined abnormal?

Malfunction diagnosis process:

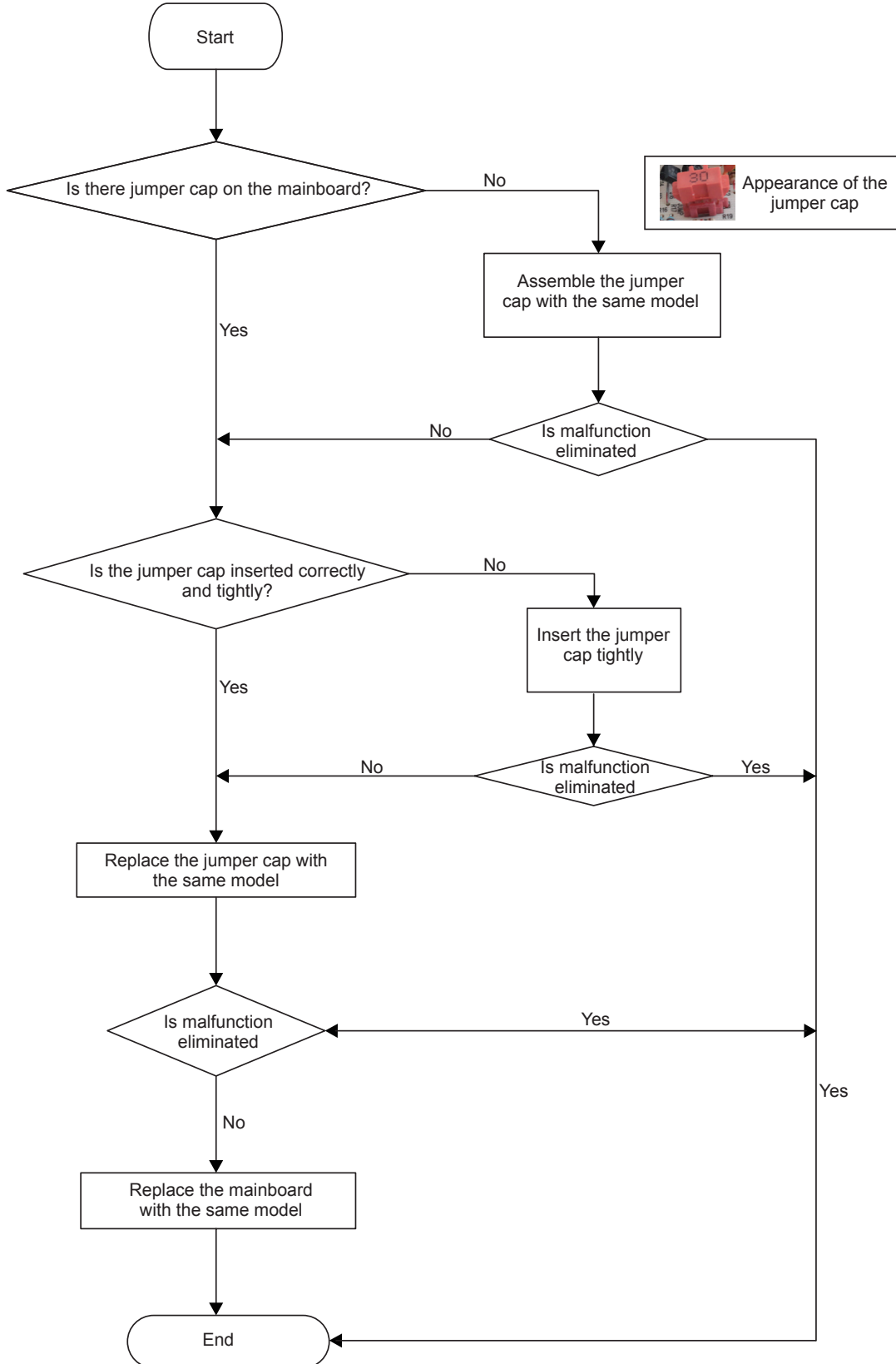

4. High temperature and overload protection (AP1 below means control board of outdoor unit) E8

Main detection points:

- If the outdoor ambient temperature is in normal range;
- If the indoor and outdoor fan are running normally;
- If the radiating environment of indoor and outdoor unit is good.

Malfunction diagnosis process:

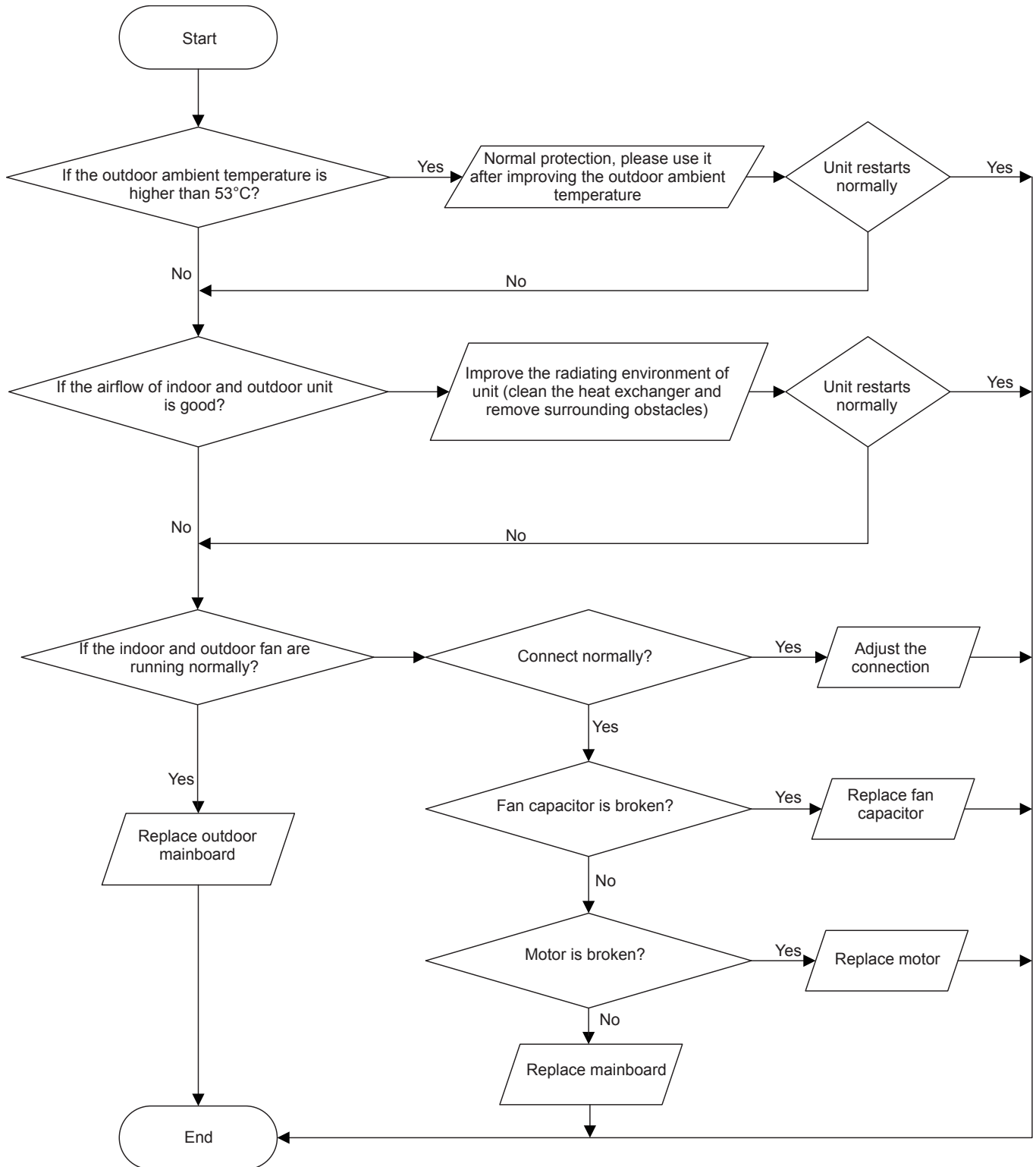

5. Malfunction of Zero-crossing Inspection Circuit Malfunction of the IDU Fan Motor U8

Main detection points:

- Instant energization after de-energization while the capacitor discharges slowly?
- The zero-cross detection circuit of the mainboard is defined abnormal?

Malfunction diagnosis process:

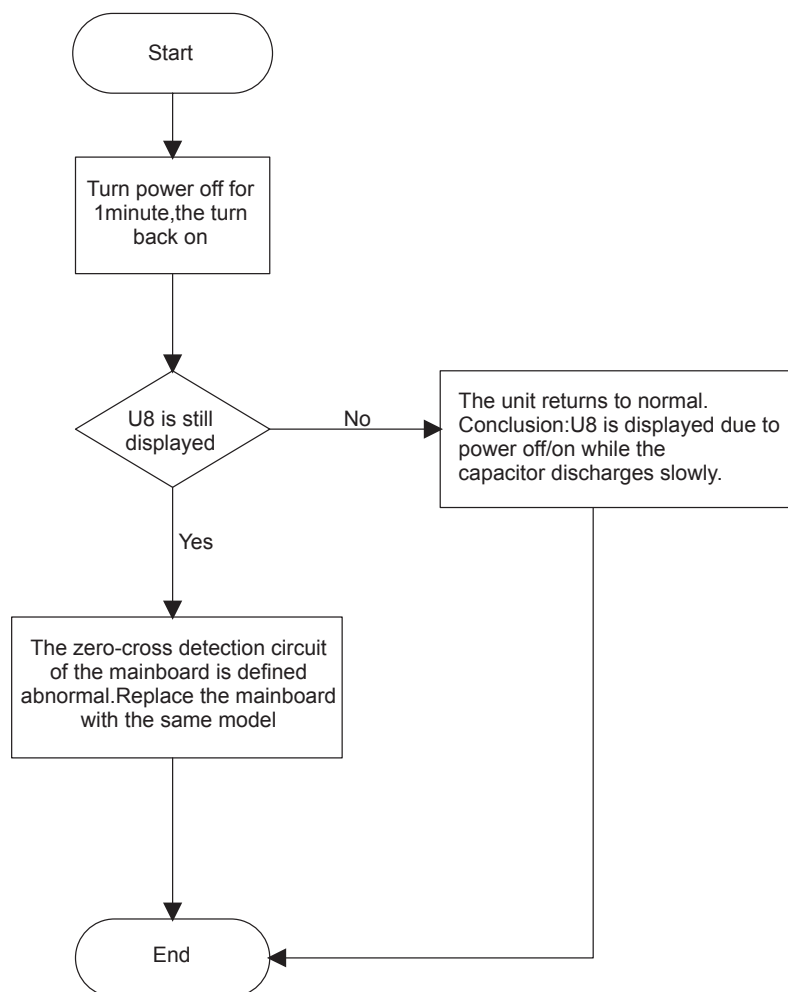

9.3 Maintenance Method for Normal Malfunction

1. Air Conditioner Can't be Started Up

Possible Causes	Discriminating Method (Air conditioner Status)	Troubleshooting
No power supply, or poor connection for power plug	After energization, operation indicator isn't bright and the buzzer can't give out sound	Confirm whether it's due to power failure. If yes, wait for power recovery. If not, check power supply circuit and make sure the power plug is connected well.
Wrong wire connection between indoor unit and outdoor unit, or poor connection for wiring terminals	Under normal power supply circumstances, operation indicator isn't bright after energization	Check the circuit according to circuit diagram and connect wires correctly. Make sure all wiring terminals are connected firmly
Electric leakage for air conditioner	After energization, room circuit breaker trips off at once	Make sure the air conditioner is grounded reliably Make sure wires of air conditioner is connected correctly Check the wiring inside air conditioner. Check whether the insulation layer of power cord is damaged; if yes, place the power cord.
Model selection for air switch is improper	After energization, air switch trips off	Select proper air switch
Malfunction of remote controller	After energization, operation indicator is bright, while no display on remote controller or buttons have no action.	Replace batteries for remote controller Repair or replace remote controller

2. Poor Cooling (Heating) for Air Conditioner

Possible Causes	Discriminating Method (Air conditioner Status)	Troubleshooting
Set temperature is improper	Observe the set temperature on remote controller	Adjust the set temperature
Rotation speed of the IDU fan motor is set too low	Small wind blow	Set the fan speed at high or medium
Filter of indoor unit is blocked	Check the filter to see it's blocked	Clean the filter
Installation position for indoor unit and outdoor unit is improper	Check whether the installation position is proper according to installation requirement for air conditioner	Adjust the installation position, and install the rainproof and sunproof for outdoor unit
Refrigerant is leaking	Discharged air temperature during cooling is higher than normal discharged wind temperature; Discharged air temperature during heating is lower than normal discharged wind temperature; Unit's pressure is much lower than regulated range	Find out the leakage causes and deal with it. Add refrigerant.
Malfunction of 4-way valve	Blow cold wind during heating	Replace the 4-way valve
Malfunction of capillary	Discharged air temperature during cooling is higher than normal discharged wind temperature; Discharged air temperature during heating is lower than normal discharged wind temperature; Unit's pressure is much lower than regulated range. If refrigerant isn't leaking, part of capillary is blocked	Replace the capillary
Flow volume of valve is insufficient	The pressure of valves is much lower than that stated in the specification	Open the valve completely
Malfunction of horizontal louver	Horizontal louver can't swing	Refer to point 3 of maintenance method for details
Malfunction of the IDU fan motor	The IDU fan motor can't operate	Refer to troubleshooting for H6 for maintenance method in details
Malfunction of the ODU fan motor	The ODU fan motor can't operate	Refer to point 4 of maintenance method for details
Malfunction of compressor	Compressor can't operate	Refer to point 5 of maintenance method for details

3. Horizontal Louver Can't Swing

Possible Causes	Discriminating Method (Air conditioner Status)	Troubleshooting
Wrong wire connection, or poor connection	Check the wiring status according to circuit diagram	Connect wires according to wiring diagram to make sure all wiring terminals are connected firmly
Stepping motor is damaged	Stepping motor can't operate	Repair or replace stepping motor
Main board is damaged	Others are all normal, while horizontal louver can't operate	Replace the main board with the same model

4. ODU Fan Motor Can't Operate

Possible causes	Discriminating method (air conditioner status)	Troubleshooting
Wrong wire connection, or poor connection	Check the wiring status according to circuit diagram	Connect wires according to wiring diagram to make sure all wiring terminals are connected firmly
Capacity of the ODU fan motor is damaged	Measure the capacity of fan capacitor with an universal meter and find that the capacity is out of the deviation range indicated on the nameplate of fan capacitor.	Replace the capacity of fan
Power voltage is a little low or high	Use universal meter to measure the power supply voltage. The voltage is a little high or low	Suggest to equip with voltage regulator
Motor of outdoor unit is damaged	When unit is on, cooling/heating performance is bad and ODU compressor generates a lot of noise and heat.	Change compressor oil and refrigerant. If no better, replace the compressor with a new one

5. Compressor Can't Operate

Possible causes	Discriminating method (air conditioner status)	Troubleshooting
Wrong wire connection, or poor connection	Check the wiring status according to circuit diagram	Connect wires according to wiring diagram to make sure all wiring terminals are connected firmly
Capacity of compressor is damaged	Measure the capacity of fan capacitor with an universal meter and find that the capacity is out of the deviation range indicated on the nameplate of fan capacitor.	Replace the compressor capacitor
Power voltage is a little low or high	Use universal meter to measure the power supply voltage. The voltage is a little high or low	Suggest to equip with voltage regulator
Coil of compressor is burnt out	Use universal meter to measure the resistance between compressor terminals and it's 0	Repair or replace compressor
Cylinder of compressor is blocked	Compressor can't operate	Repair or replace compressor

6. Air Conditioner is Leaking

Possible causes	Discriminating method (air conditioner status)	Troubleshooting
Drain pipe is blocked	Water leaking from indoor unit	Eliminate the foreign objects inside the drain pipe
Drain pipe is broken	Water leaking from drain pipe	Replace drain pipe
Wrapping is not tight	Water leaking from the pipe connection place of indoor unit	Wrap it again and bundle it tightly

7. Abnormal Sound and Vibration

Possible causes	Discriminating method (air conditioner status)	Troubleshooting
When turn on or turn off the unit, the panel and other parts will expand and there's abnormal sound	There's the sound of "PAPA"	Normal phenomenon. Abnormal sound will disappear after a few minutes.
When turn on or turn off the unit, there's abnormal sound due to flow of refrigerant inside air conditioner	Water-running sound can be heard	Normal phenomenon. Abnormal sound will disappear after a few minutes.
Foreign objects inside the indoor unit or there're parts touching together inside the indoor unit	There's abnormal sound fro indoor unit	Remove foreign objects. Adjust all parts' position of indoor unit, tighten screws and stick damping plaster between connected parts
Foreign objects inside the outdoor unit or there're parts touching together inside the outdoor unit	There's abnormal sound fro outdoor unit	Remove foreign objects. Adjust all parts' position of outdoor unit, tighten screws and stick damping plaster between connected parts
Short circuit inside the magnetic coil	During heating, the way valve has abnormal electromagnetic sound	Replace magnetic coil
Abnormal shake of compressor	Outdoor unit gives out abnormal sound	Adjust the support foot mat of compressor, tighten the bolts
Abnormal sound inside the compressor	Abnormal sound inside the compressor	If add too much refrigerant during maintenance, please reduce refrigerant properly. Replace compressor for other circumstances.

10. Exploded View and Parts List

10.1 Indoor Unit

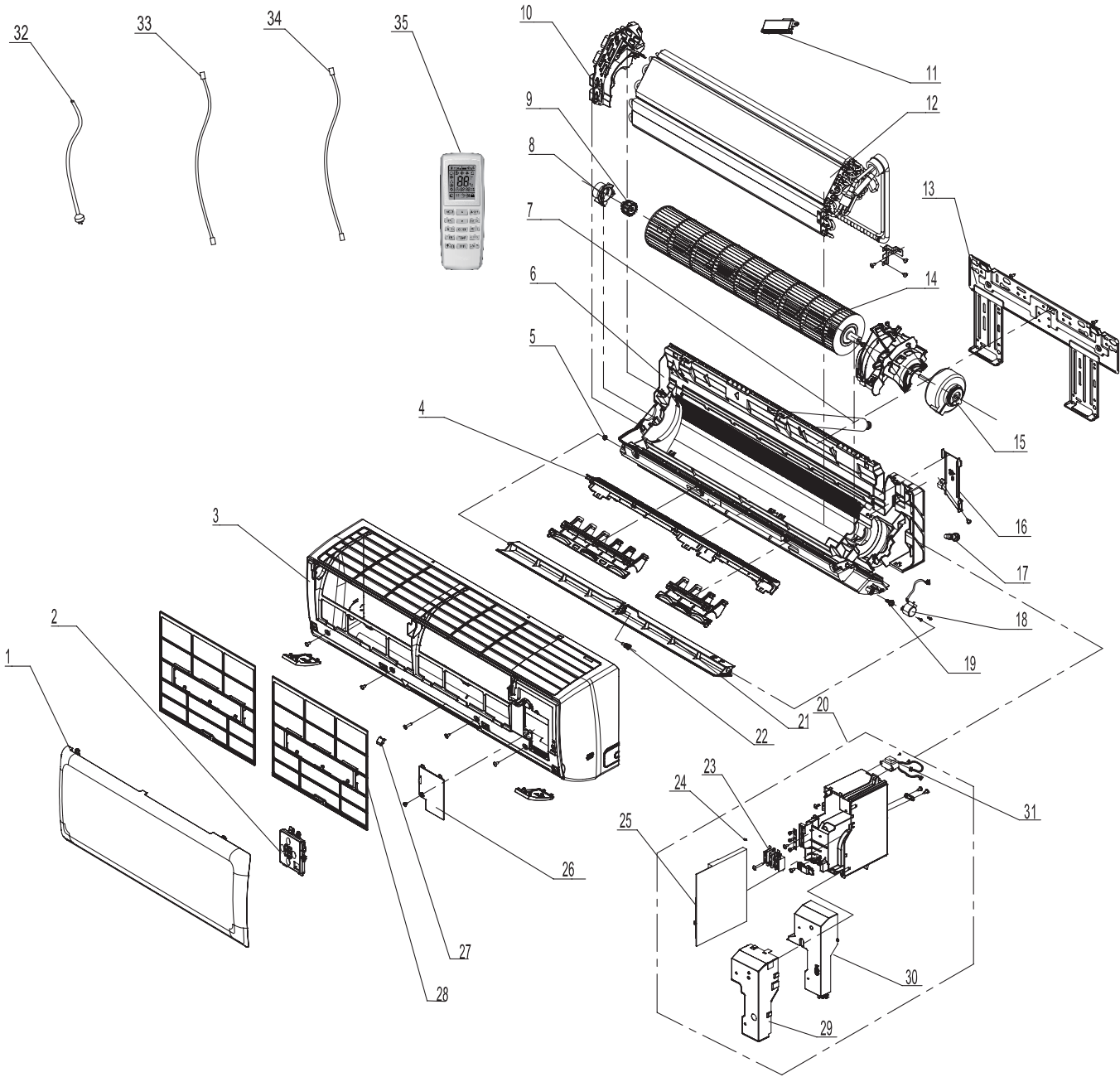

The component picture is only for reference; please refer to the actual product.

No.	Description	Part Code		Qty
		LM009CI-100P432-1	LM012CI-100P432-1	
		Product Code	Product Code	
		Y6916	Y6918	
1	Front Panel	27230003851	27230003811	1
2	Display Board	30565260	30565260	1
3	Front Case Assy	00000200041	00000200040	1
4	Helicoid Tongue	26112509	26112508	1
5	Left Axile Bush	10512037	10512037	1
6	Rear Case assy	20022732	20162010	1
7	Drainage Hose	0523001408	0523001408	1
8	Ring of Bearing	26152022	26152022	1
9	O-Gasket sub-assy of Bearing	7651205102	7651205102	1
10	Evaporator Support	24212180	24212180	1
11	Cold Plasma Generator	/	/	/
12	Evaporator Assy	0100297201	0110010009503	1
13	Wall Mounting Frame	01363013	01252043	1
14	Cross Flow Fan	10352058	10352059	1
15	Fan Motor	1501211501	1501208905	1
16	Connecting pipe clamp	2611216401	2611216401	1
17	Rubber Plug (Water Tray)	76712012	76712012	1
18	Stepping Motor	1521212901	1521212901	1
19	Crank	73012005	73012005	1
20	Electric Box Assy	10000203804_L36544	10000202977_L36544	1
21	Guide Louver	1051232501	1051276301	1
22	Axile Bush	10542036	10542036	1
23	Terminal Board	42010276	42010276	1
24	Jumper	4202300106	4202300115	1
25	Main Board	30135966	30135966	1
26	Electric Box Cover Sub-Assy	01402065	01402065	1
27	Screw Cover	2425203001	2425203001	1
28	Filter Sub-Assy	11122157	11122219	2
29	Shield Cover of Electric Box Cover	01592150	01592150	1
30	Electric Box Cover	20112207	20112207	1
31	Transformer	43110053	43110053	1
32	Power Cord	4002048918	4002048918	1
33	Connecting Cable	4002054010	4002054010	0
34	Connecting Cable	/	/	/
35	Remote Controller	30510112_L36544	30510112_L36544	1

Above data is subject to change without notice.

10.2 Outdoor Unit

LM009CO-100P432-1

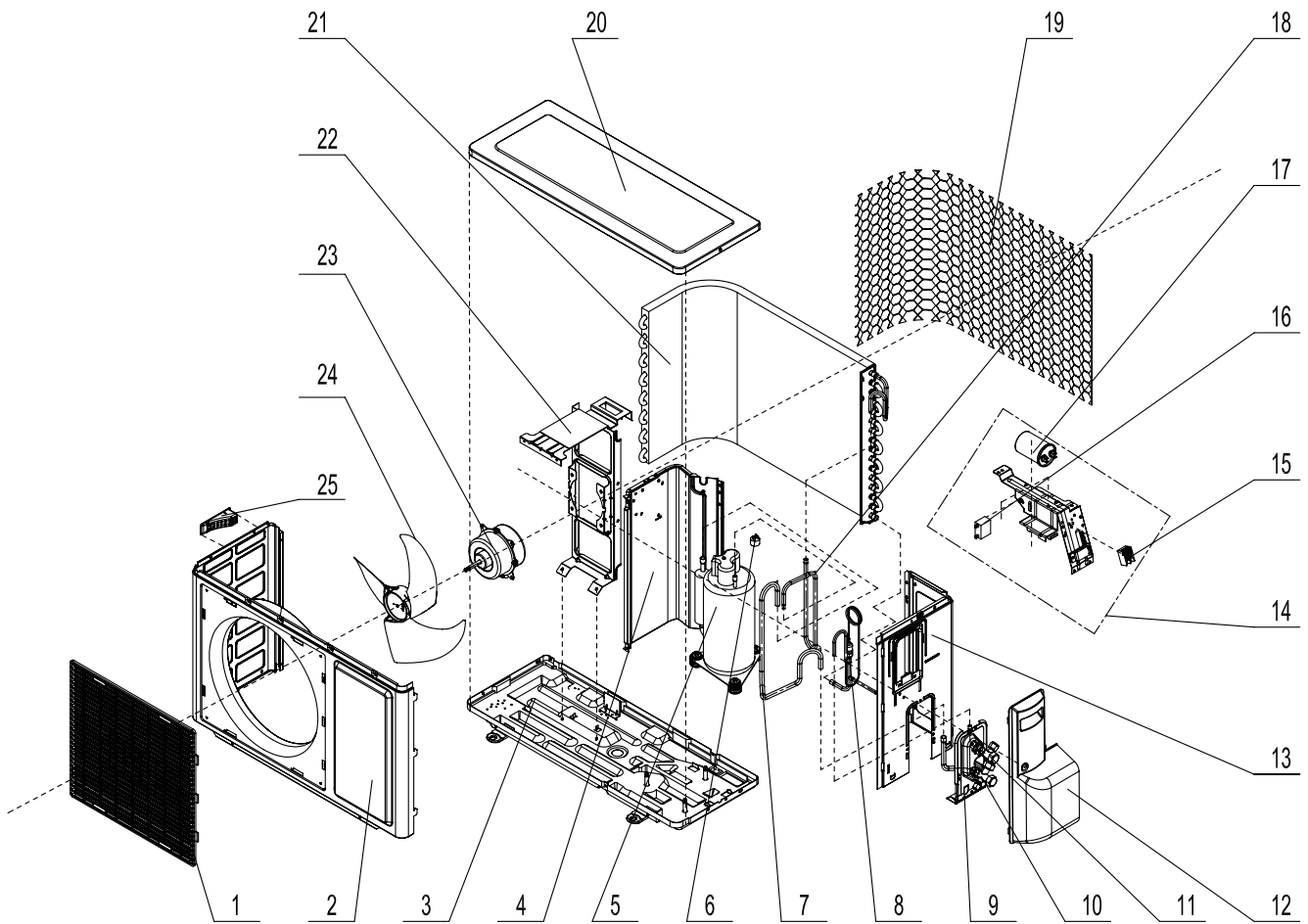

The component picture is only for reference; please refer to the actual product.

NO.	Description	Part Code	Qty
		LM009CO-100P432-1	
		Product Code Y6917	
1	Front Grill	22263002	1
2	Front Panel	01533255P	1
3	Chassis Sub-assy	02803229P	1
4	Clapboard Sub-Assy	01233207	1
5	Compressor and Fittings	00103362	1
6	Overload Protector	00180259	1
7	Inhalation Tube Sub-assy	03001000404	1
8	Capillary Sub-assy	03000600525	1
9	Valve Support	01713041	1
10	Valve	07100003	1
11	Valve	07100005	1
12	Big Handle	2623304202	1
13	Right Side Plate Sub-Assy	01303243	1
14	Electric Box Assy	10000203226	1
15	Terminal Board	42011154	1
16	Capacitor CBB61S	3301074702	1
17	Capacitor CBB65	33000081	1
18	Discharge Tube	03500800807	1
19	Rear Grill	01473041	1
20	Top Cover Sub-Assy	01253045P	1
21	Condenser Assy	01100200558	1
22	Motor Support Sub-Assy	01703204	1
23	Fan Motor	15013004	1
24	Axial Flow Fan	10333002	1
25	Small Handle	26233100	1

Above data is subject to change without notice.

NO.	Description	Part Code	Qty
		LM012CO-100P432-1	
		Product Code	
		Y6919	
1	Front Grill	22413008	1
2	Front Panel	01533034P	1
3	Chassis Sub-assy	01700000180P	1
4	Compressor and fittings	00103370	1
5	Compressor Gasket	76710208	/
6	Inhalation Tube	03500600758	1
7	Discharge Tube	03500800796	1
8	Capillary Sub-Assy	03000600518	1
9	Valve	07100003	1
10	Valve	07100003	1
11	Big Handle	262334332	1
12	Valve Support	0170308901P	1
13	Right Side Plate Sub-Assy	0130317201P	1
14	Electric Box Assy	10000201422	1
15	Terminal Board	42011154	1
16	Capacitor CBB65	3300008101	1
17	Capacitor CBB61	3301074710	1
18	Rear grill	01473009	1
19	Condenser Assy	01100200551	1
20	Top Cover Sub-Assy	0125309901	1
21	Clapboard Sub-Assy	01233066	1
22	Motor Support	01703103	1
23	Fan Motor	1501306729	1
24	Small Handle	26233100	1
25	Axial Flow Fan	10333427	1

Above data is subject to change without notice.

11. Removal Procedure

11.1 Removal Procedure of Indoor Unit

⚠ Caution: discharge the refrigerant completely before removal.

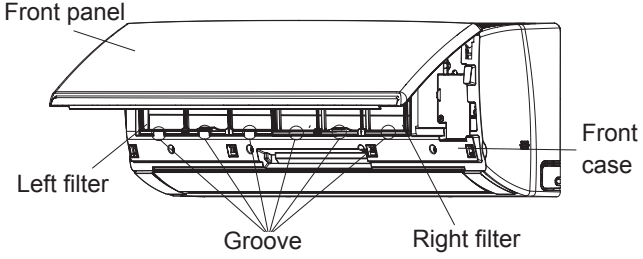
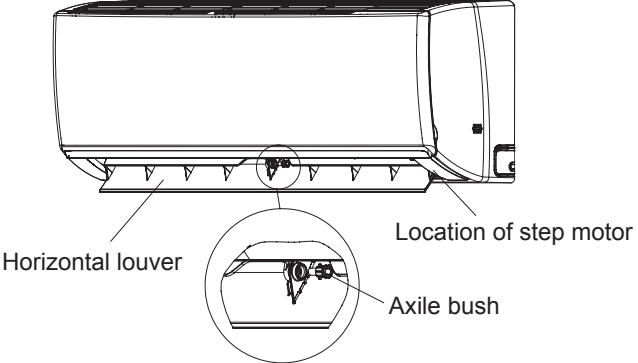
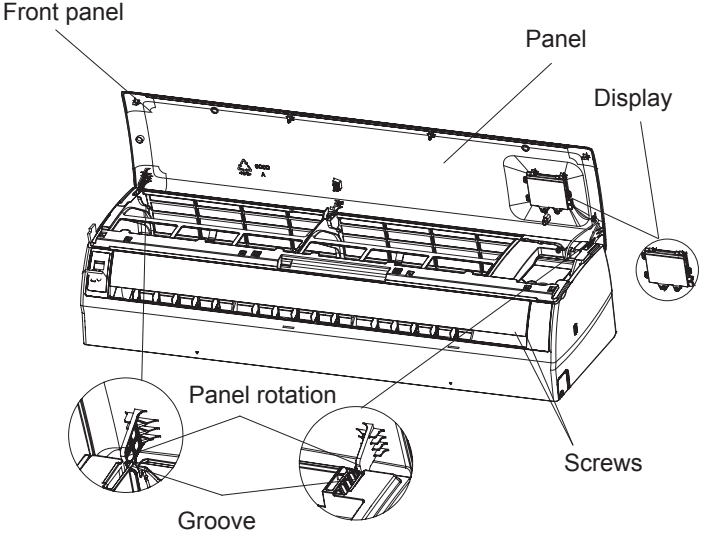
Step	Procedure	Diagram
<p>1. Remove filter assembly</p> <p>Open the front panel. Push the left filter and right filter until they are separate from the groove on the front panel. Remove the left filter and right filter respectively.</p>	 <p>Labels: Front panel, Left filter, Groove, Right filter, Front case</p>	
<p>2. Remove horizontal louver</p> <p>Push out the axle bush on horizontal louver. Bend the horizontal louver with hand and then separate the horizontal louver from the crankshaft of step motor to remove it.</p>	 <p>Labels: Horizontal louver, Location of step motor, Axile bush</p>	
<p>3. Remove panel</p> <p>a Screw off the 2 screws that are locking the display board.</p> <p>b Separate the panel rotation shaft from the groove fixing the front panel and then removes the front panel.</p>	 <p>Labels: Front panel, Panel, Display, Screws, Panel rotation, Groove</p>	

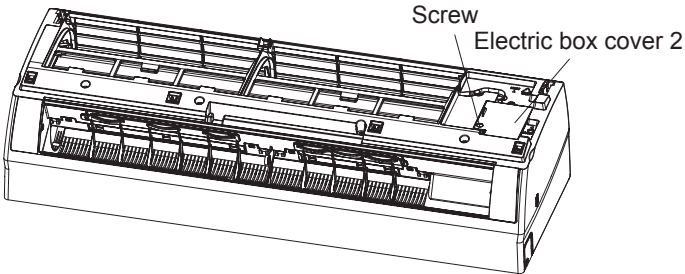
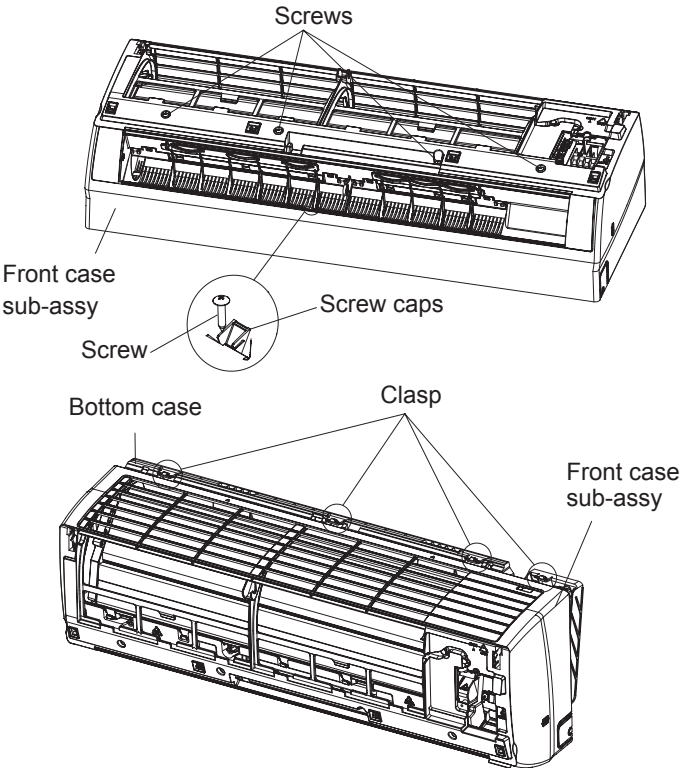
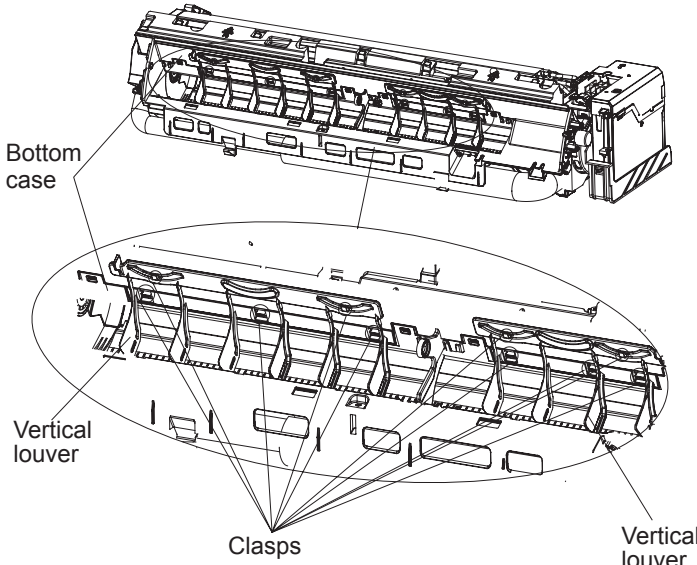
Steps	Procedure	
4. Remove electric box cover 2	Remove the screws on the electric box cover 2 to remove the electric box cover 2.	 <p>Screw Electric box cover 2</p>
5. Remove front case sub-assy	<p>a Remove the screws fixing front case.</p> <p>Note: 1. Open the screw caps before removing the screws around the air outlet. 2. The quantity of screws fixing the front case sub-assy is different for different models.</p> <p>b Loosen the connection clasps between front case sub-assy and bottom case. Lift up the front case sub-assy and take it out.</p>	 <p>Screws Front case sub-assy Screw caps Screw Bottom case Clasp Front case sub-assy</p>
6. Remove vertical louver	Loosen the connection clasps between vertical louver and bottom case to remove vertical louver.	 <p>Bottom case Vertical louver Clasps Vertical louver</p>

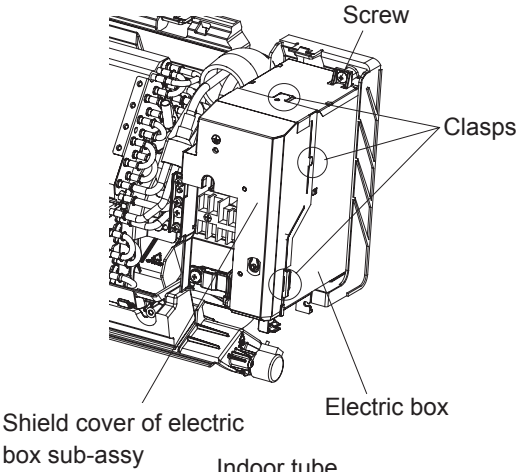
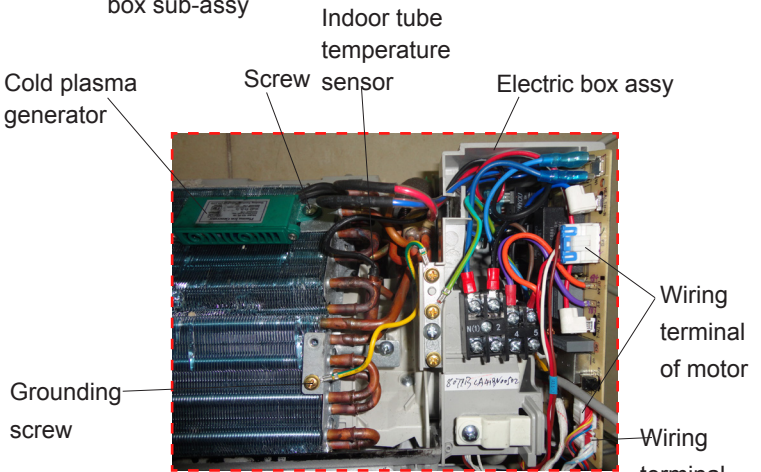
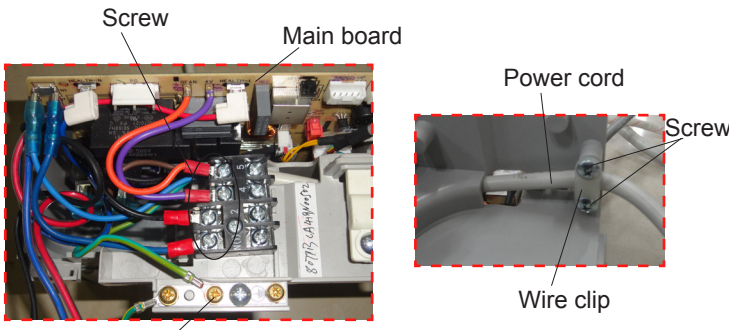
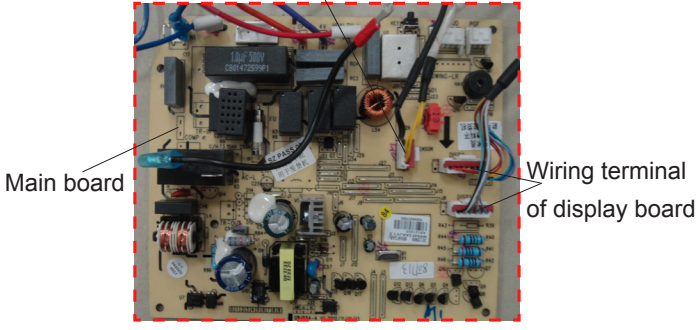
Steps	Procedure
7. Remove electric box assy	
a	<p>Loosen the connection clasps between shield cover of electric box sub-assy and electric box, and then remove the shield cover of electric box sub-assy. Remove the screw fixing electric box assy .</p> 
b	<ol style="list-style-type: none"> ① Remove the cold plasma generator by screwing off one locking screw on the generator. ② Take off the indoor tube temperature sensor. ③ Screw off one grounding screw. ④ Remove the wiring terminals of motor and stepping motor. ⑤ Remove the electric box assy. 
c	<p>Twist off the screws that are locking lead wire and rotate the electric box assy. Twist off the screws that are locking wire clip. Loosen the power cord and remove its wiring terminal. Lift up the main board and take it off.</p> 
d	<p>Remove the display board by taking out its wiring terminal. Remove temperature sensor by taking out its wiring terminal.</p> 

Steps	Procedure	Image
	<p>Instruction: Some wiring terminal of this product is with lock catch and other devices. The pulling method is as below:</p> <p>1.Remove the soft sheath for some terminals at first, hold the circlip and then pull out the terminals.</p> <p>2.Pull out the holder for some terminals at first (holder is not available for some wiring terminal), hold the connector and then pull the terminal.</p>	<p>Circlip</p> <p>Soft sheath</p> <p>Holder</p> <p>Connector</p>
<p>8. Remove evaporator assy</p>		<p>Screws</p> <p>Evaporator assy</p>
<p>a</p>	<p>Remove 3 screws fixing evaporator assy.</p>	
<p>b</p>	<p>At the back of the unit, remove the screw fixing connection pipe clamp and then remove the connection pipe clamp.</p>	<p>Connection pipe clamp</p> <p>Screw</p>
<p>c</p>	<p>First remove the left side of evaporator from the groove of bottom shell and then remove the right side from the clasp on the bottom shell.</p>	<p>Groove</p> <p>Bottom shell</p> <p>Evaporator assy</p> <p>Clasp</p>
<p>d</p>	<p>Adjust the position of connection pipe on evaporator slightly and then lift the evaporator upwards to remove it.</p>	<p>Connection pipe</p>

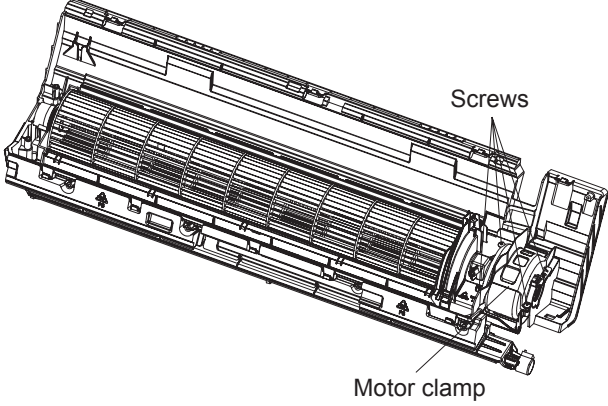
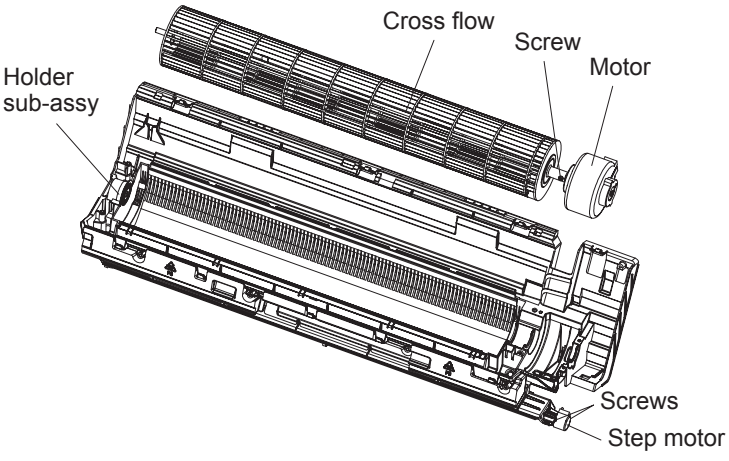
Steps	Procedure
9. Remove motor and cross flow blade	
a	<p>Remove the screws fixing motor clamp and then remove the motor clamp.</p> 
b	<p>Remove the screws at the connection place of cross flow blade and motor; lift the motor and cross flow blade upwards to remove them. Remove the bearing holder sub-assy. Remove the screw fixing step motor and then remove the step motor.</p> 

11.2 Removal Procedure of Outdoor Unit

LM009CO-100P432-1

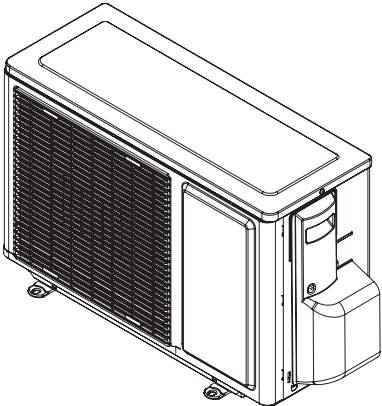
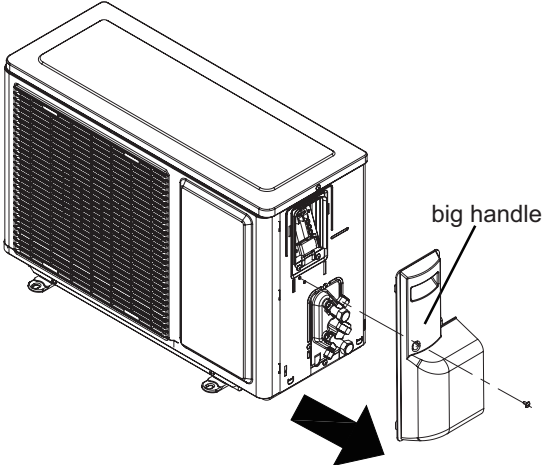
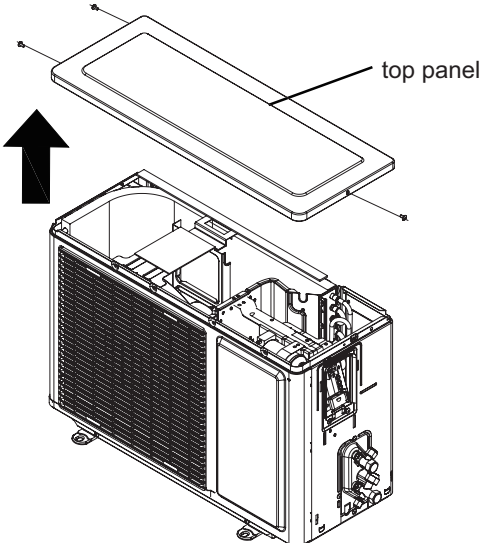
Steps	Procedure	
<p>1.Remove big handle</p>		
<p>a</p>	<p>Before disassembly.</p>	
<p>b</p>	<p>Remove the screw fixing the big handle. Remove the big handle.</p>	
<p>2.Remove top cover</p>		
	<p>Remove the screws connecting the top panel with the front panel and right side panel. Remove the top cover.</p>	

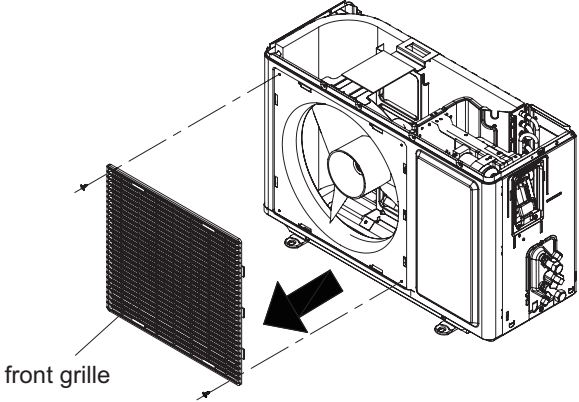
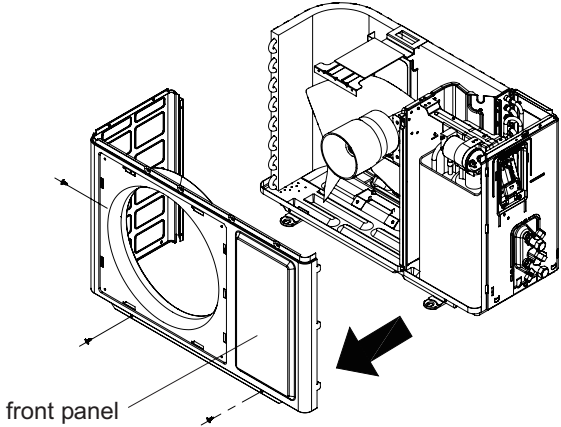
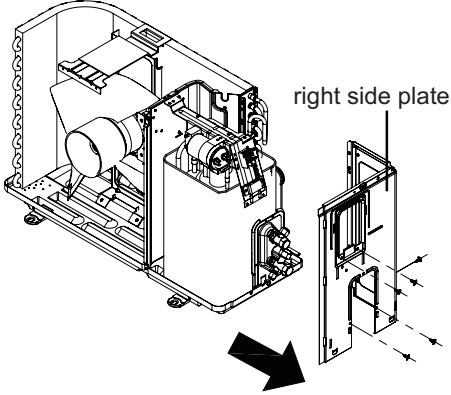
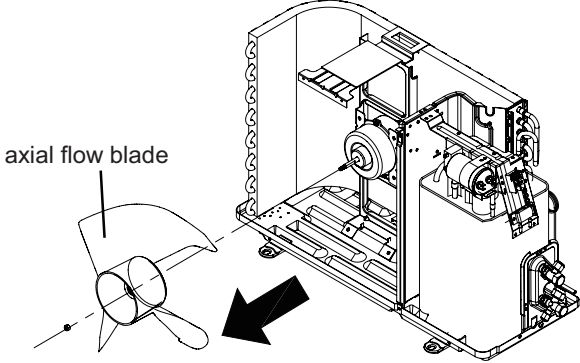
Steps	Procedure
<p>3.Remove front grille</p>	<p>Remove screws fixing the front grille and the front panel. Remove the grille.</p>  <p>front grille</p>
<p>4.Remove front panel</p>	<p>Remove screws connecting the front panel with the chassis and the motor support. Remove the front panel.</p>  <p>front panel</p>
<p>5.Remove right side plate</p>	<p>Remove screws connecting the right side plate with the chassis, the valve support and the electric box. Remove the right side plate.</p>  <p>right side plate</p>
<p>6.Remove axial flow blade</p>	<p>Remove the nut on the blade. Remove the axial flow blade.</p>  <p>axial flow blade</p>

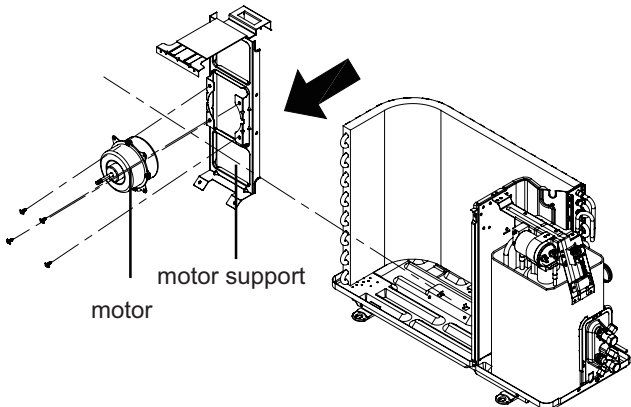
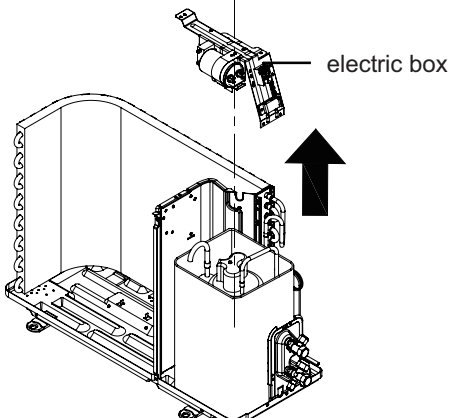
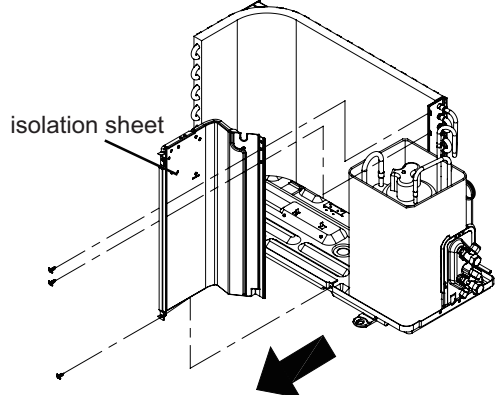
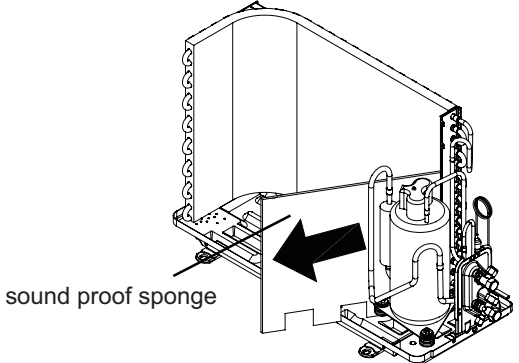
Steps	Procedure	
<p>7.Remove motor and motor support</p>		
	<p>Remove the tapping screws fixing the motor; disconnect the leading wire insert of the motor. Remove the motor. Remove the tapping screws fixing the motor support. Lift the motor support to remove it.</p>	 <p>motor support</p> <p>motor</p>
<p>8.Remove electric box</p>		
	<p>Remove screws fixing the electric box subassembly. Loosen the wire bundle; unplug the wiring terminals and lift the electric box to remove it.</p>	 <p>electric box</p>
<p>9.Remove isolation sheet</p>		
	<p>Remove the 3 screws fixing the isolation sheet. Remove the isolation sheet.</p>	 <p>isolation sheet</p>
<p>10.Remove sound proof sponge</p>		
	<p>Remove the soundproof sponge wrapping the compressor.</p>	 <p>sound proof sponge</p>

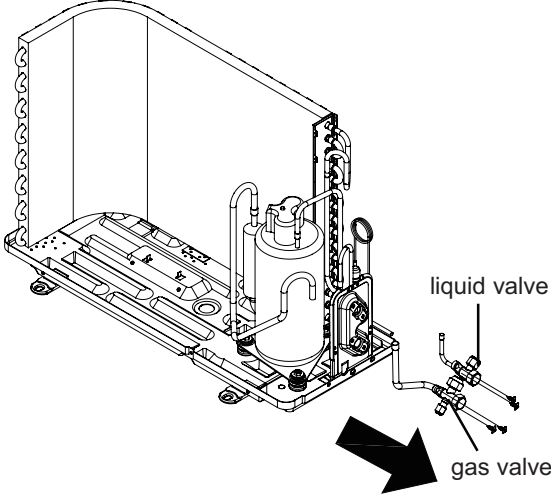
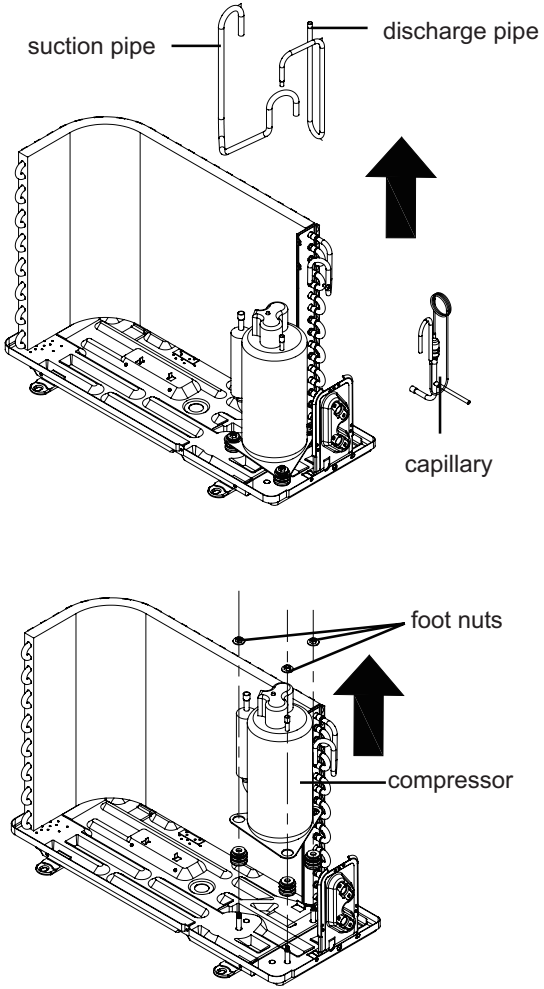
Steps	Procedure	
<p>11.Remove gas valve and liquid valve</p>	<p>Unsolder the capillary, valves and the outlet pipe of condenser. Do not block the capillary with welding slag during unsoldering. Remove the 2 screws fixing the gas valve. Unsolder the gas valve and the air-return pipe . (NOTE: Discharge the refrigerant completely before unsoldering; when unsoldering, wrap the gas valve with wet cloth to avoid damage to the valve caused by high temperature). Remove the 2 screws fixing the liquid valve and unsolder the liquid valve and the Y-type pipe to remove the liquid valve.</p>	
<p>12.Remove compressor</p>	<p>a Unsolder the pipes connecting with the compressor.</p> <p>b Remove the foot nuts on the compressor. Remove the compressor.</p>	

LM012CO-100P432-1

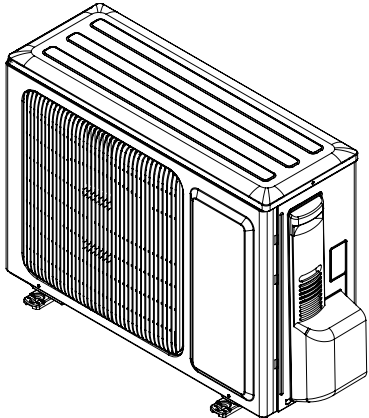
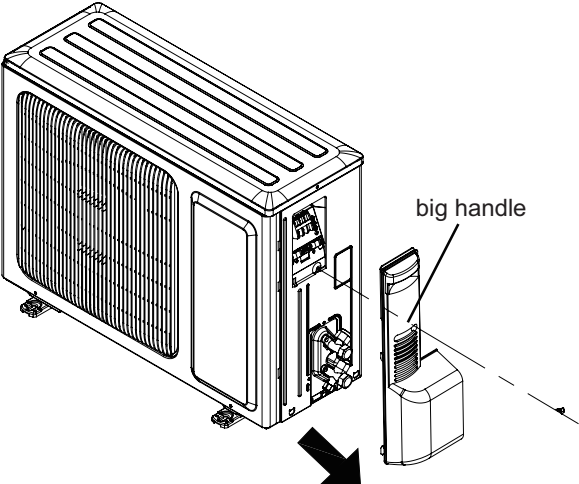
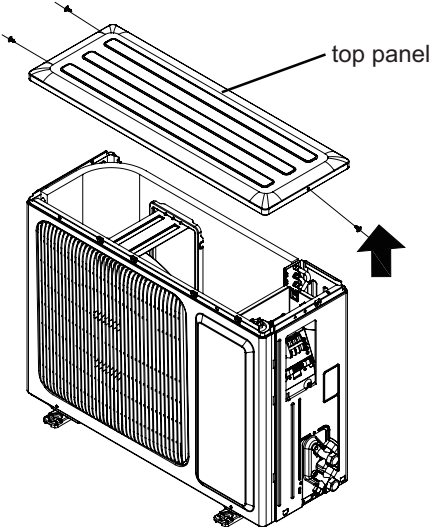
Step	Procedure
<p>1. Before disassembly</p>	
<p>2. Remove big handle</p>	<p>Remove the connection screw fixing the big handle and then remove the handle.</p> 
<p>3. Remove top panel</p>	<p>Remove connection screws connecting the top panel with the front panel and the right side plate, and then remove the top panel.</p> 

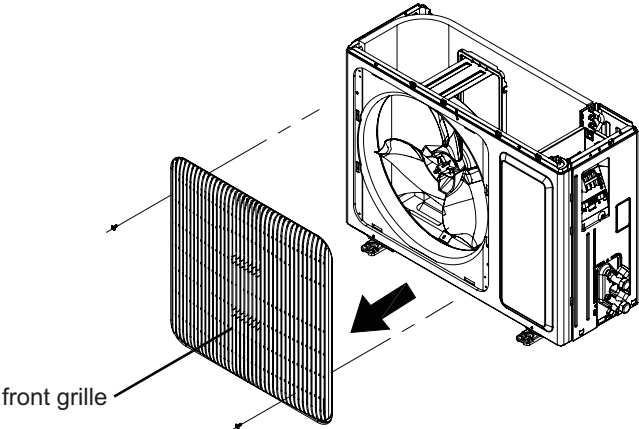
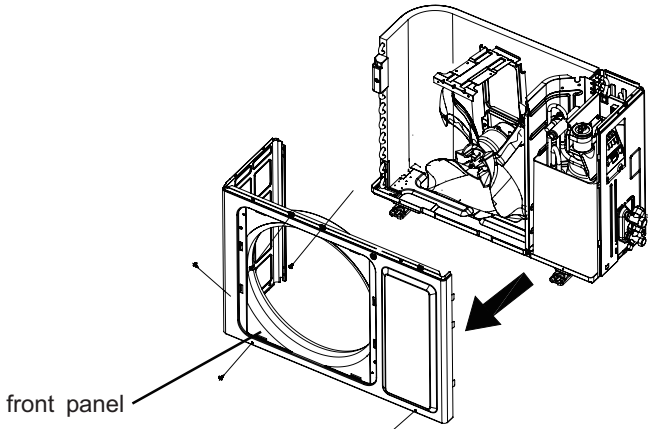
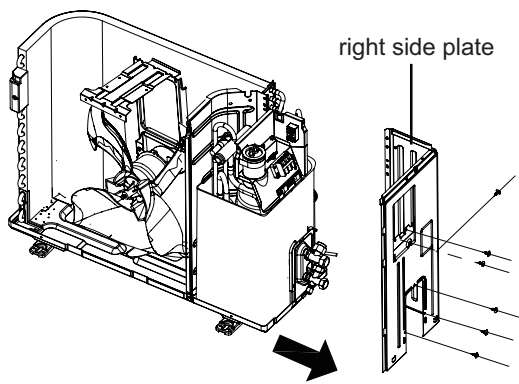
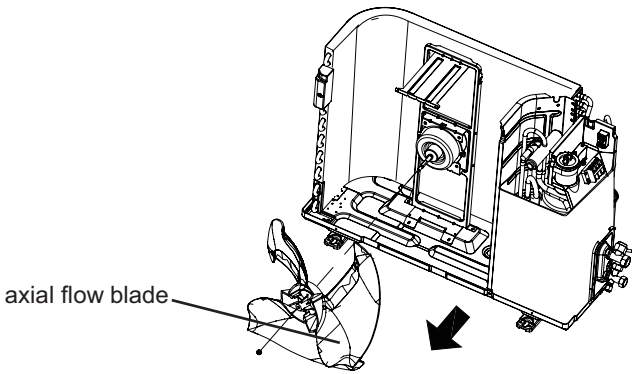
Step	Procedure
<p>4. Remove front grille</p>	<p>Remove connection screws between the front grille and the front panel. Then remove the front grille.</p>  <p>front grille</p>
<p>5. Remove front panel</p>	<p>Remove connection screws connecting the front panel with the chassis and the motor support, and then remove the front panel.</p>  <p>front panel</p>
<p>6. Remove right side plate</p>	<p>Remove connection screws connecting the right side plate with the chassis, the valve support and the electric box. Then remove the right side plate.</p>  <p>right side plate</p>
<p>7. Remove axial flow blade</p>	<p>Remove the nut on the blade and then remove the axial flow blade.</p>  <p>axial flow blade</p>

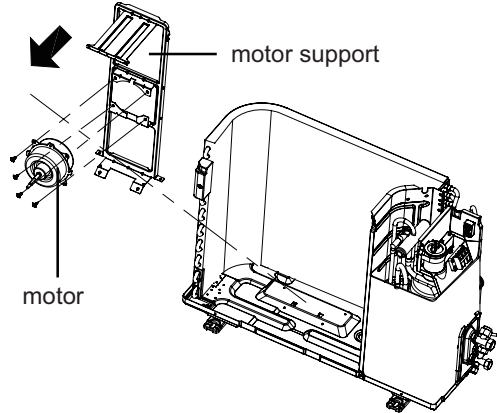
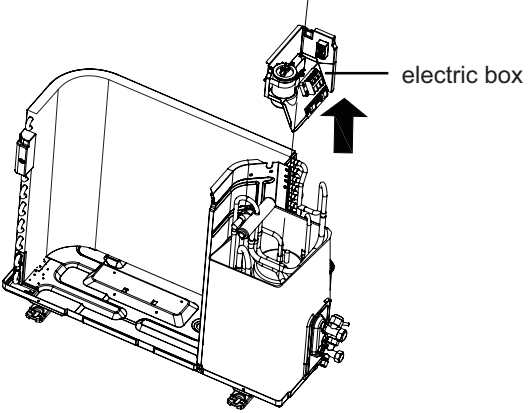
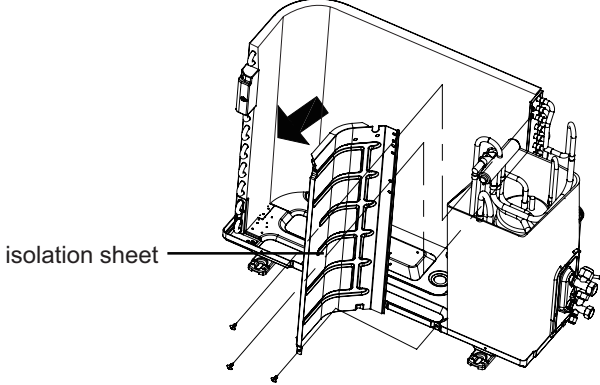
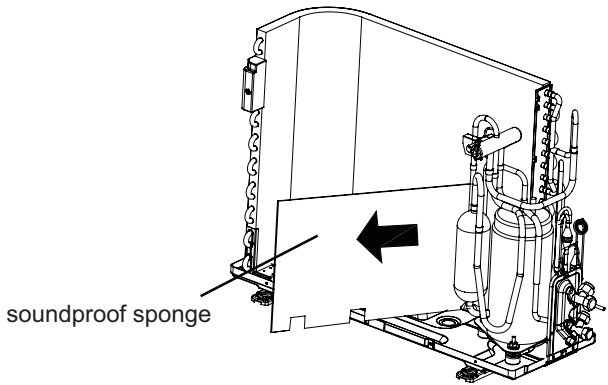
Step	Procedure
<p>8. Remove motor and motor support</p>	<p>Remove the 4 tapping screws fixing the motor and disconnect the leading wire insert of the motor. Then remove the motor. Remove the 2 tapping screws fixing the motor support and lift the motor support to remove it.</p> 
<p>9. Remove electric box</p>	<p>Remove screws fixing the electric box subassembly; loosen the wire bundle and unplug the wiring terminals. Then lift the electric box to remove it.</p> 
<p>10. Remove isolation sheet</p>	<p>Remove the 3 screws fixing the isolation sheet and then remove the isolation sheet.</p> 
<p>11. Remove soundproof sponge</p>	<p>Remove the soundproof sponge wrapping the compressor.</p> 

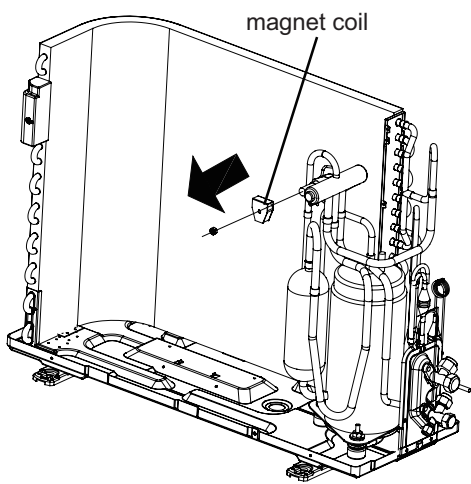
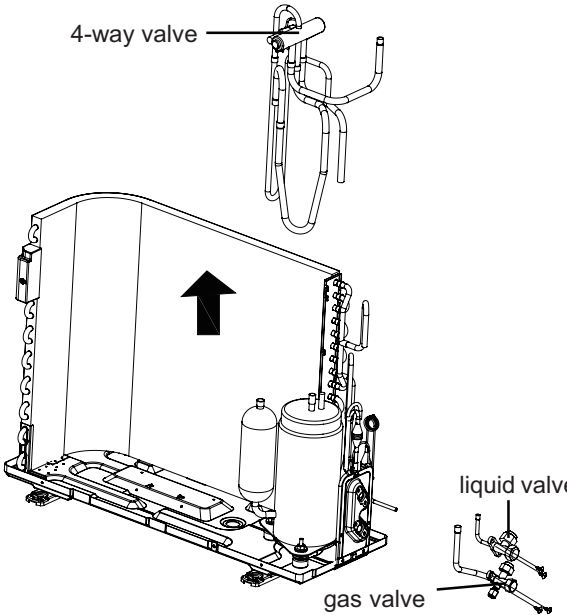
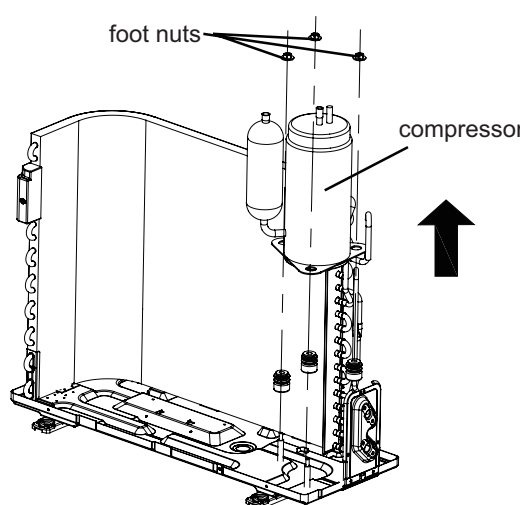
Step	Procedure
<p>12. Remove magnet coil</p>	<p>Remove the screw fixing the magnet coil and then remove the coil.</p> 
<p>13. Remove valves and 4-way valve subassembly</p>	<p>Unsolder welding joint connecting the capillary, the valve and the outlet pipe of condenser to remove the capillary. Do not block the capillary with welding slag during unsoldering. Remove the 2 screws fixing the gas valve and unsolder the welding point between the gas valve and the air-return pipe to remove the gas valve. (NOTE: Discharge the refrigerant completely before unsoldering; when unsoldering, wrap the gas valve with a wet cloth completely to avoid damage to the valve caused by high temperature). Remove the 2 screws fixing the liquid valve and unsolder the welding joint connecting the liquid valve to the Y-type pipe to remove the liquid valve. Unsolder the welding joint connecting the 4-way valve, the compressor and the condenser to remove the 4-way valve.</p> 
<p>14. Remove compressor</p>	<p>Remove the foot nuts on the compressor and then remove the compressor.</p> 

Appendix:

Appendix 1: Reference Sheet of Celsius and Fahrenheit

Conversion formula for Fahrenheit degree and Celsius degree: $T_f = T_c \times 1.8 + 32$

Set temperature

Fahrenheit display temperature (°F)	Fahrenheit (°F)	Celsius(°C)	Fahrenheit display temperature (°F)	Fahrenheit (°F)	Celsius(°C)	Fahrenheit display temperature (°F)	Fahrenheit (°F)	Celsius(°C)
61	60.8	16	69/70	69.8	21	78/79	78.8	26
62/63	62.6	17	71/72	71.6	22	80/81	80.6	27
64/65	64.4	18	73/74	73.4	23	82/83	82.4	28
66/67	66.2	19	75/76	75.2	24	84/85	84.2	29
68	68	20	77	77	25	86	86	30

Ambient temperature

Fahrenheit display temperature (°F)	Fahrenheit (°F)	Celsius(°C)	Fahrenheit display temperature (°F)	Fahrenheit (°F)	Celsius(°C)	Fahrenheit display temperature (°F)	Fahrenheit (°F)	Celsius(°C)
32/33	32	0	55/56	55.4	13	79/80	78.8	26
34/35	33.8	1	57/58	57.2	14	81	80.6	27
36	35.6	2	59/60	59	15	82/83	82.4	28
37/38	37.4	3	61/62	60.8	16	84/85	84.2	29
39/40	39.2	4	63	62.6	17	86/87	86	30
41/42	41	5	64/65	64.4	18	88/89	87.8	31
43/44	42.8	6	66/67	66.2	19	90	89.6	32
45	44.6	7	68/69	68	20	91/92	91.4	33
46/47	46.4	8	70/71	69.8	21	93/94	93.2	34
48/49	48.2	9	72	71.6	22	95/96	95	35
50/51	50	10	73/74	73.4	23	97/98	96.8	36
52/53	51.8	11	75/76	75.2	24	99	98.6	37
54	53.6	12	77/78	77	25			

Appendix 2: Configuration of Connection Pipe

1. Standard length of connection pipe

- 5m, 7.5m, 8m.

2. Min. length of connection pipe is 3m.

3. Max. length of connection pipe and max. high difference.

4. The additional refrigerant oil and refrigerant charging required after prolonging connection pipe

- After the length of connection pipe is prolonged for 10m at the basis of standard length, you should add 5ml of refrigerant oil for each additional 5m of connection pipe.

- The calculation method of additional refrigerant charging amount (on the basis of liquid pipe):

Cooling capacity	Max length of connection pipe	Max height difference
5000 Btu/h(1465 W)	15 m	5 m
7000 Btu/h(2051 W)	15 m	5 m
9000 Btu/h(2637 W)	15 m	10 m
12000 Btu/h(3516 W)	20 m	10 m
18000 Btu/h(5274 W)	25 m	10 m
24000 Btu/h(7032 W)	25 m	10 m
28000 Btu/h(8204 W)	30 m	10 m
36000 Btu/h(10548 W)	30 m	20 m
42000 Btu/h(12306 W)	30 m	20 m
48000 Btu/h(14064 W)	30 m	20 m

- When the length of connection pipe is above 5m, add refrigerant according to the prolonged length of liquid pipe. The additional refrigerant charging amount per meter is different according to the diameter of liquid pipe. See the following sheet.

- Additional refrigerant charging amount = prolonged length of liquid pipe X additional refrigerant charging amount per meter

Additional refrigerant charging amount for R22, R407C, R410A and R134a			
Diameter of connection pipe		Outdoor unit throttle	
Liquid pipe(mm)	Gas pipe(mm)	Cooling only(g/m)	Cooling and heating(g/m)
Φ6	Φ9.5 or Φ12	15	20
Φ6 or Φ9.5	Φ16 or Φ19	15	20
Φ12	Φ19 or Φ22.2	30	120
Φ16	Φ25.4 or Φ31.8	60	120
Φ19	/	250	250
Φ22.2	/	350	350

Appendix 3: Pipe Expanding Method

⚠ Note:

Improper pipe expanding is the main cause of refrigerant leakage. Please expand the pipe according to the following steps:

A: Cut the pip

- Confirm the pipe length according to the distance of indoor unit and outdoor unit.
- Cut the required pipe with pipe cutter.

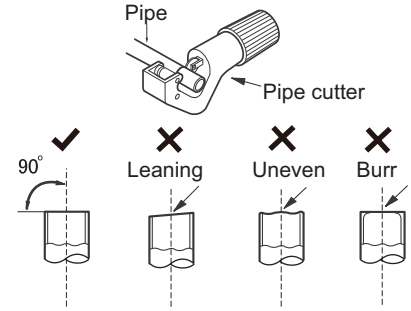

B: Remove the burrs

- Remove the burrs with shaper and prevent the burrs from getting into the pipe.

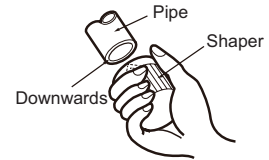

C: Put on suitable insulating pipe

D: Put on the union nut

- Remove the union nut on the indoor connection pipe and outdoor valve; install the union nut on the pipe.

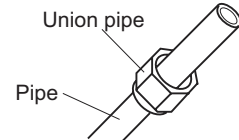

E: Expand the port

- Expand the port with expander.

⚠ Note:

- "A" is different according to the diameter, please refer to the sheet below:

Outer diameter(mm)	A(mm)	
	Max	Min
Φ6 - 6.35 (1/4")	1.3	0.7
Φ9.52 (3/8")	1.6	1.0
Φ12 - 12.70 (1/2")	1.8	1.0
Φ16 - 15.88 (5/8")	2.4	2.2

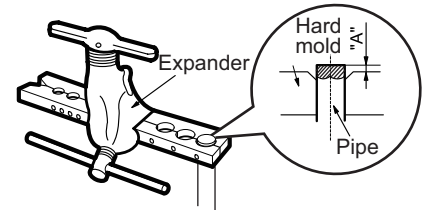

F: Inspection

- Check the quality of expanding port. If there is any blemish, expand the port again according to the steps above.

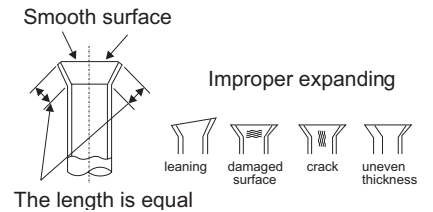

Appendix 4: List of Resistance for Temperature Sensor

Resistance Table of Ambient Temperature Sensor for Indoor and Outdoor (15K)

Temp(°C)	Resistance(kΩ)	Temp(°C)	Resistance(kΩ)	Temp(°C)	Resistance(kΩ)	Temp(°C)	Resistance(kΩ)
-19	138.1	20	18.75	59	3.848	98	1.071
-18	128.6	21	17.93	60	3.711	99	1.039
-17	121.6	22	17.14	61	3.579	100	1.009
-16	115	23	16.39	62	3.454	101	0.98
-15	108.7	24	15.68	63	3.333	102	0.952
-14	102.9	25	15	64	3.217	103	0.925
-13	97.4	26	14.36	65	3.105	104	0.898
-12	92.22	27	13.74	66	2.998	105	0.873
-11	87.35	28	13.16	67	2.896	106	0.848
-10	82.75	29	12.6	68	2.797	107	0.825
-9	78.43	30	12.07	69	2.702	108	0.802
-8	74.35	31	11.57	70	2.611	109	0.779
-7	70.5	32	11.09	71	2.523	110	0.758
-6	66.88	33	10.63	72	2.439	111	0.737
-5	63.46	34	10.2	73	2.358	112	0.717
-4	60.23	35	9.779	74	2.28	113	0.697
-3	57.18	36	9.382	75	2.206	114	0.678
-2	54.31	37	9.003	76	2.133	115	0.66
-1	51.59	38	8.642	77	2.064	116	0.642
0	49.02	39	8.297	78	1.997	117	0.625
1	46.6	40	7.967	79	1.933	118	0.608
2	44.31	41	7.653	80	1.871	119	0.592
3	42.14	42	7.352	81	1.811	120	0.577
4	40.09	43	7.065	82	1.754	121	0.561
5	38.15	44	6.791	83	1.699	122	0.547
6	36.32	45	6.529	84	1.645	123	0.532
7	34.58	46	6.278	85	1.594	124	0.519
8	32.94	47	6.038	86	1.544	125	0.505
9	31.38	48	5.809	87	1.497	126	0.492
10	29.9	49	5.589	88	1.451	127	0.48
11	28.51	50	5.379	89	1.408	128	0.467
12	27.18	51	5.197	90	1.363	129	0.456
13	25.92	52	4.986	91	1.322	130	0.444
14	24.73	53	4.802	92	1.282	131	0.433
15	23.6	54	4.625	93	1.244	132	0.422
16	22.53	55	4.456	94	1.207	133	0.412
17	21.51	56	4.294	95	1.171	134	0.401
18	20.54	57	4.139	96	1.136	135	0.391
19	19.63	58	3.99	97	1.103	136	0.382

Resistance Table of Tube Temperature Sensors for Indoor and Outdoor (20K)

Temp(°C)	Resistance(kΩ)	Temp(°C)	Resistance(kΩ)	Temp(°C)	Resistance(kΩ)	Temp(°C)	Resistance(kΩ)
-19	181.4	20	25.01	59	5.13	98	1.427
-18	171.4	21	23.9	60	4.948	99	1.386
-17	162.1	22	22.85	61	4.773	100	1.346
-16	153.3	23	21.85	62	4.605	101	1.307
-15	145	24	20.9	63	4.443	102	1.269
-14	137.2	25	20	64	4.289	103	1.233
-13	129.9	26	19.14	65	4.14	104	1.198
-12	123	27	18.13	66	3.998	105	1.164
-11	116.5	28	17.55	67	3.861	106	1.131
-10	110.3	29	16.8	68	3.729	107	1.099
-9	104.6	30	16.1	69	3.603	108	1.069
-8	99.13	31	15.43	70	3.481	109	1.039
-7	94	32	14.79	71	3.364	110	1.01
-6	89.17	33	14.18	72	3.252	111	0.983
-5	84.61	34	13.59	73	3.144	112	0.956
-4	80.31	35	13.04	74	3.04	113	0.93
-3	76.24	36	12.51	75	2.94	114	0.904
-2	72.41	37	12	76	2.844	115	0.88
-1	68.79	38	11.52	77	2.752	116	0.856
0	65.37	39	11.06	78	2.663	117	0.833
1	62.13	40	10.62	79	2.577	118	0.811
2	59.08	41	10.2	80	2.495	119	0.77
3	56.19	42	9.803	81	2.415	120	0.769
4	53.46	43	9.42	82	2.339	121	0.746
5	50.87	44	9.054	83	2.265	122	0.729
6	48.42	45	8.705	84	2.194	123	0.71
7	46.11	46	8.37	85	2.125	124	0.692
8	43.92	47	8.051	86	2.059	125	0.674
9	41.84	48	7.745	87	1.996	126	0.658
10	39.87	49	7.453	88	1.934	127	0.64
11	38.01	50	7.173	89	1.875	128	0.623
12	36.24	51	6.905	90	1.818	129	0.607
13	34.57	52	6.648	91	1.736	130	0.592
14	32.98	53	6.403	92	1.71	131	0.577
15	31.47	54	6.167	93	1.658	132	0.563
16	30.04	55	5.942	94	1.609	133	0.549
17	28.68	56	5.726	95	1.561	134	0.535
18	27.39	57	5.519	96	1.515	135	0.521
19	26.17	58	5.32	97	1.47	136	0.509

Resistance Table of Discharge Temperature Sensor for Outdoor (50K)

Temp(°C)	Resistance(kΩ)	Temp(°C)	Resistance(kΩ)	Temp(°C)	Resistance(kΩ)	Temp(°C)	Resistance(kΩ)
-29	853.5	10	98	49	18.34	88	4.75
-28	799.8	11	93.42	50	17.65	89	4.61
-27	750	12	89.07	51	16.99	90	4.47
-26	703.8	13	84.95	52	16.36	91	4.33
-25	660.8	14	81.05	53	15.75	92	4.20
-24	620.8	15	77.35	54	15.17	93	4.08
-23	580.6	16	73.83	55	14.62	94	3.96
-22	548.9	17	70.5	56	14.09	95	3.84
-21	516.6	18	67.34	57	13.58	96	3.73
-20	486.5	19	64.33	58	13.09	97	3.62
-19	458.3	20	61.48	59	12.62	98	3.51
-18	432	21	58.77	60	12.17	99	3.41
-17	407.4	22	56.19	61	11.74	100	3.32
-16	384.5	23	53.74	62	11.32	101	3.22
-15	362.9	24	51.41	63	10.93	102	3.13
-14	342.8	25	49.19	64	10.54	103	3.04
-13	323.9	26	47.08	65	10.18	104	2.96
-12	306.2	27	45.07	66	9.83	105	2.87
-11	289.6	28	43.16	67	9.49	106	2.79
-10	274	29	41.34	68	9.17	107	2.72
-9	259.3	30	39.61	69	8.85	108	2.64
-8	245.6	31	37.96	70	8.56	109	2.57
-7	232.6	32	36.38	71	8.27	110	2.50
-6	220.5	33	34.88	72	7.99	111	2.43
-5	209	34	33.45	73	7.73	112	2.37
-4	198.3	35	32.09	74	7.47	113	2.30
-3	199.1	36	30.79	75	7.22	114	2.24
-2	178.5	37	29.54	76	7.00	115	2.18
-1	169.5	38	28.36	77	6.76	116	2.12
0	161	39	27.23	78	6.54	117	2.07
1	153	40	26.15	79	6.33	118	2.02
2	145.4	41	25.11	80	6.13	119	1.96
3	138.3	42	24.13	81	5.93	120	1.91
4	131.5	43	23.19	82	5.75	121	1.86
5	125.1	44	22.29	83	5.57	122	1.82
6	119.1	45	21.43	84	5.39	123	1.77
7	113.4	46	20.6	85	5.22	124	1.73
8	108	47	19.81	86	5.06	125	1.68
9	102.8	48	19.06	87	4.90	126	1.64

JF00302630



America's Premier Climate Comfort Brand since 1895

Visit us at www.lennox.com, or contact us at 1-877-726-0024.

© 2014 Lennox Industries Inc.
For a complete list of the registered and common law trademarks owned by Lennox Industries Inc., please visit www.lennox.com.

For product improvement, specifications and appearance in this manual are subject to change without prior notice.