



SUBMITTAL DATA - INDOOR UNIT
VELD007N4U
VRF LOW STATIC FAN COIL EVAPORATOR

Job Name: _____
Location: _____
Schedule No.: _____
System Designation: _____

Engineer: _____
Architect: _____
Date: _____
For: ___ Reference ___ Approval ___ Review ___ Construction

FEATURES

- Auto Addressing installation
- Auto Restart
- Detachable Blower Motor
- Integrated Condensate Pump
- Built-in Electronic Expansion Valve
- LED Display
- Washable Filter
- Water Overflow Protection
- Anti-Freezing Protection

PRODUCT WARRANTY

All covered components - one year limited warranty

SPECIFICATIONS

PERFORMANCE

Cooling Capacity* (Btu/h)		7,506
Heating Capacity* (Btu/h)		8,530
Airflow (CFM)	High	265
	Medium	206
	Low	147
External Static Pressure	Pa	0 - 30
	in. WC	0 - 0.12
Sound Pressure Level (dBA)	H / M / L	31/28/25

ELECTRICAL DATA

Power Supply (V / Hz / Ph)	220-240/50/1 - 208-230/60/1
MOP (A)	6
Rated Current (A)	Cooling 0.2
	Heating 0.2

DIMENSIONS

Unit Dimensions (in)	Height	7 3/4
	Width	27 1/2
	Depth	24 1/4
Liquid Pipe Connection (in)		1/4
Gas Pipe Connection (in)		3/8
Shipping Weight (lb)		59.5
Net Weight (lb)		48.5

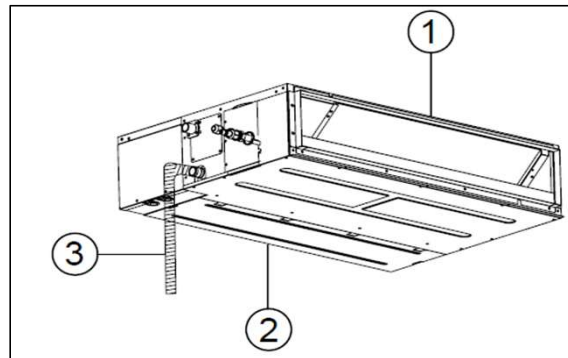
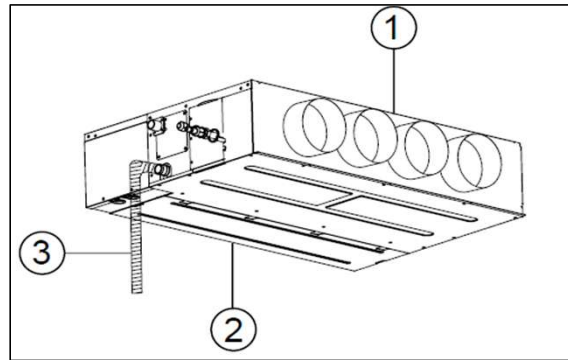

1. Air Outlet
2. Air-Return Opening
3. Drain Pipe

NOTES:

*Cooling and Heating Capacity data is rated at the following conditions:

Cooling: 80 °F DB / 67 °F WB Indoor, 95 °F DB Outdoor

Heating: 70 °F DB Indoor, 47 °F DB

NOTE – Due to Lennox' ongoing commitment to quality, Specifications, Ratings and Dimensions subject to change without notice and without incurring liability. Improper installation, adjustment, alteration, service or maintenance can cause property damage or personal injury. Installation and service must be performed by a qualified installer and servicing agency. ©2014 Lennox Industries Inc.



SUBMITTAL DATA - INDOOR UNIT
VELD007N4U
VRF LOW STATIC FAN COIL EVAPORATOR

DIMENSIONAL DRAWINGS

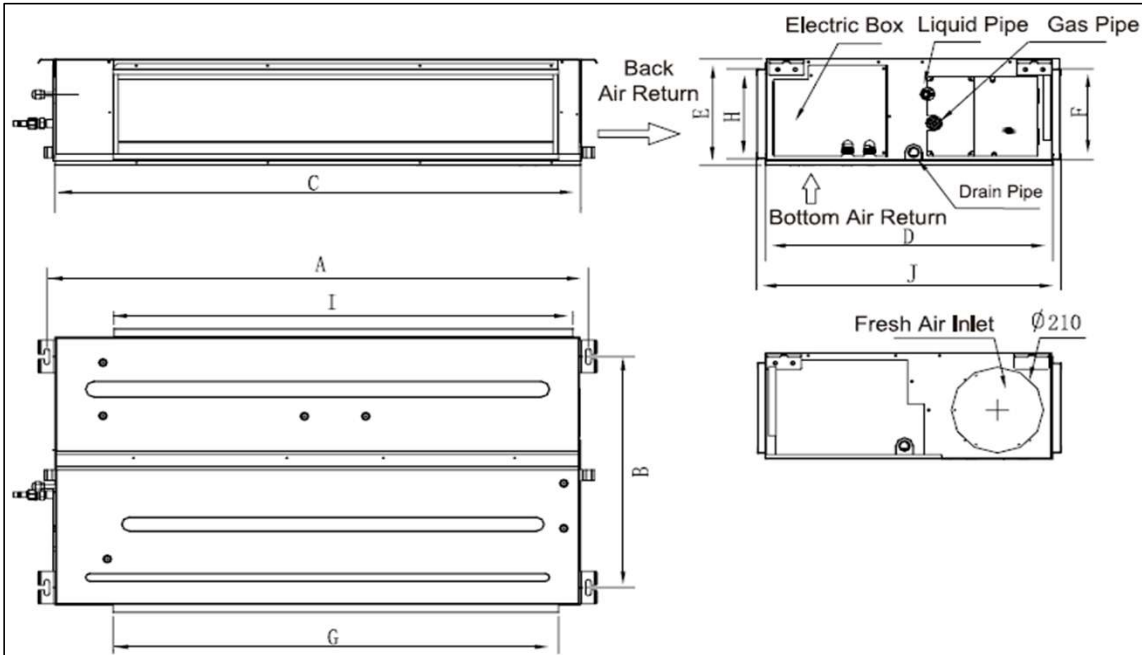

	mm	in
A	742	29.21
B	491	19.33
C	700	27.56
D	615	24.21
E	200	7.87
F	121	4.76
G	528	20.79
H	161	6.34
I	580	22.83

NOTE – Due to Lennox' ongoing commitment to quality, Specifications, Ratings and Dimensions subject to change without notice and without incurring liability. Improper installation, adjustment, alteration, service or maintenance can cause property damage or personal injury. Installation and service must be performed by a qualified installer and servicing agency. ©2014 Lennox Industries Inc.



SUBMITTAL DATA - INDOOR UNIT
VELD008N4U
VRF LOW STATIC FAN COIL EVAPORATOR

Job Name: _____
Location: _____
Schedule No.: _____
System Designation: _____

Engineer: _____
Architect: _____
Date: _____
For: ___ Reference ___ Approval ___ Review ___ Construction

FEATURES

- Auto Addressing installation
- Auto Restart
- Detachable Blower Motor
- Integrated Condensate Pump
- Built-in Electronic Expansion Valve
- LED Display
- Washable Filter
- Water Overflow Protection
- Anti-Freezing Protection

PRODUCT WARRANTY

All covered components - one year limited warranty

SPECIFICATIONS

PERFORMANCE

Cooling Capacity* (Btu/h)		8,530
Heating Capacity* (Btu/h)		9,554
Airflow (CFM)	High	265
	Medium	206
	Low	147
External Static Pressure	Pa	0 - 30
	in. WC	0 - 0.12
Sound Pressure Level (dBA)	H / M / L	31/28/25

ELECTRICAL DATA

Power Supply (V / Hz / Ph)	220-240/50/1 - 208-230/60/1
MOP (A)	6
Rated Current (A)	Cooling 0.2
	Heating 0.2

DIMENSIONS

Unit Dimensions (in)	Height	7 3/4
	Width	27 1/2
	Depth	24 1/4
Liquid Pipe Connection (in)		1/4
Gas Pipe Connection (in)		3/8
Shipping Weight (lb)		59.5
Net Weight (lb)		48.5

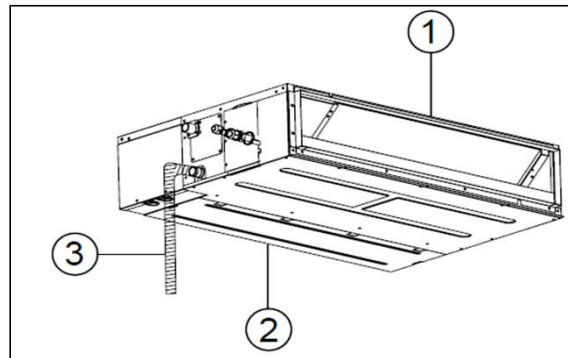
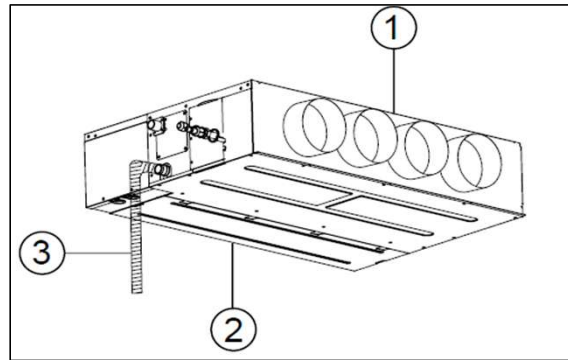

1. Air Outlet
2. Air-Return Opening
3. Drain Pipe

NOTES:

*Cooling and Heating Capacity data is rated at the following conditions:

Cooling: 80 °F DB / 67 °F WB Indoor, 95 °F DB Outdoor

Heating: 70 °F DB Indoor, 47 °F DB

NOTE – Due to Lennox' ongoing commitment to quality, Specifications, Ratings and Dimensions subject to change without notice and without incurring liability. Improper installation, adjustment, alteration, service or maintenance can cause property damage or personal injury. Installation and service must be performed by a qualified installer and servicing agency. ©2014 Lennox Industries Inc.



SUBMITTAL DATA - INDOOR UNIT
VELD008N4U
VRF LOW STATIC FAN COIL EVAPORATOR

DIMENSIONAL DRAWINGS

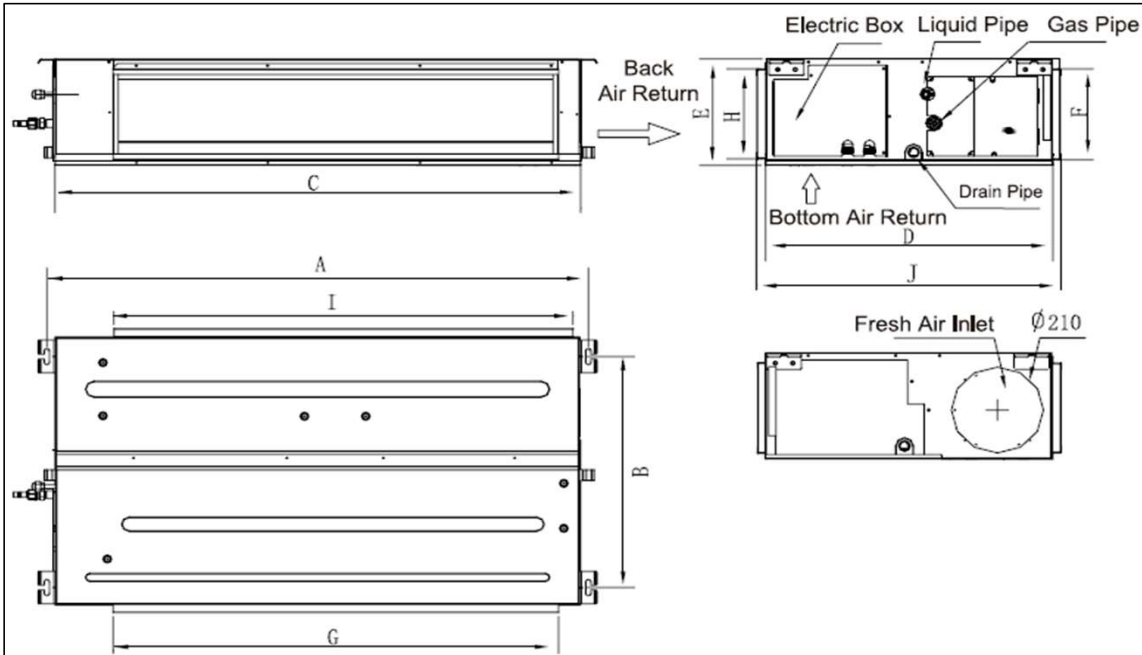

	mm	in
A	742	29.21
B	491	19.33
C	700	27.56
D	615	24.21
E	200	7.87
F	121	4.76
G	528	20.79
H	161	6.34
I	580	22.83

NOTE – Due to Lennox' ongoing commitment to quality, Specifications, Ratings and Dimensions subject to change without notice and without incurring liability. Improper installation, adjustment, alteration, service or maintenance can cause property damage or personal injury. Installation and service must be performed by a qualified installer and servicing agency. ©2014 Lennox Industries Inc.



SUBMITTAL DATA - INDOOR UNIT
VELD009N4U
VRF LOW STATIC FAN COIL EVAPORATOR

Job Name: _____
Location: _____
Schedule No.: _____
System Designation: _____

Engineer: _____
Architect: _____
Date: _____
For: ___ Reference ___ Approval ___ Review ___ Construction

FEATURES

- Auto Addressing installation
- Auto Restart
- Detachable Blower Motor
- Integrated Condensate Pump
- Built-in Electronic Expansion Valve
- LED Display
- Washable Filter
- Water Overflow Protection
- Anti-Freezing Protection

PRODUCT WARRANTY

All covered components - one year limited warranty

SPECIFICATIONS

PERFORMANCE

Cooling Capacity* (Btu/h)		9,554
Heating Capacity* (Btu/h)		10,918
Airflow (CFM)	High	265
	Medium	206
	Low	147
External Static Pressure	Pa	0 - 30
	in. WC	0 - 0.12
Sound Pressure Level (dBA)	H / M / L	31/28/25

ELECTRICAL DATA

Power Supply (V / Hz / Ph)	220-240/50/1 - 208-230/60/1
MOP (A)	6
Rated Current (A)	Cooling 0.2
	Heating 0.2

DIMENSIONS

Unit Dimensions (in)	Height	7 3/4
	Width	27 1/2
	Depth	24 1/4
Liquid Pipe Connection (in)		1/4
Gas Pipe Connection (in)		3/8
Shipping Weight (lb)		59.5
Net Weight (lb)		48.5

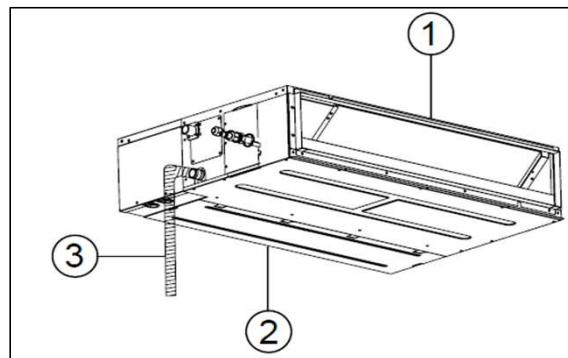
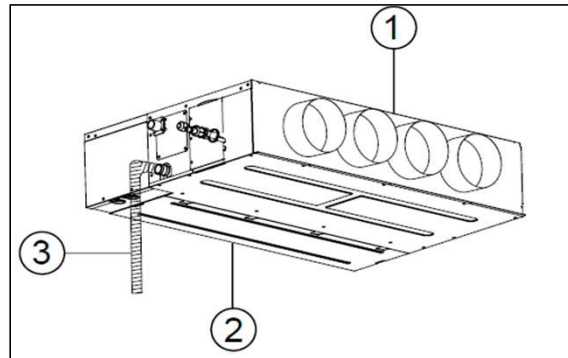

1. Air Outlet
2. Air-Return Opening
3. Drain Pipe

NOTES:

*Cooling and Heating Capacity data is rated at the following conditions:

Cooling: 80 °F DB / 67 °F WB Indoor, 95 °F DB Outdoor

Heating: 70 °F DB Indoor, 47 °F DB

NOTE – Due to Lennox' ongoing commitment to quality, Specifications, Ratings and Dimensions subject to change without notice and without incurring liability. Improper installation, adjustment, alteration, service or maintenance can cause property damage or personal injury. Installation and service must be performed by a qualified installer and servicing agency. ©2014 Lennox Industries Inc.



SUBMITTAL DATA - INDOOR UNIT
VELD009N4U
VRF LOW STATIC FAN COIL EVAPORATOR

DIMENSIONAL DRAWINGS

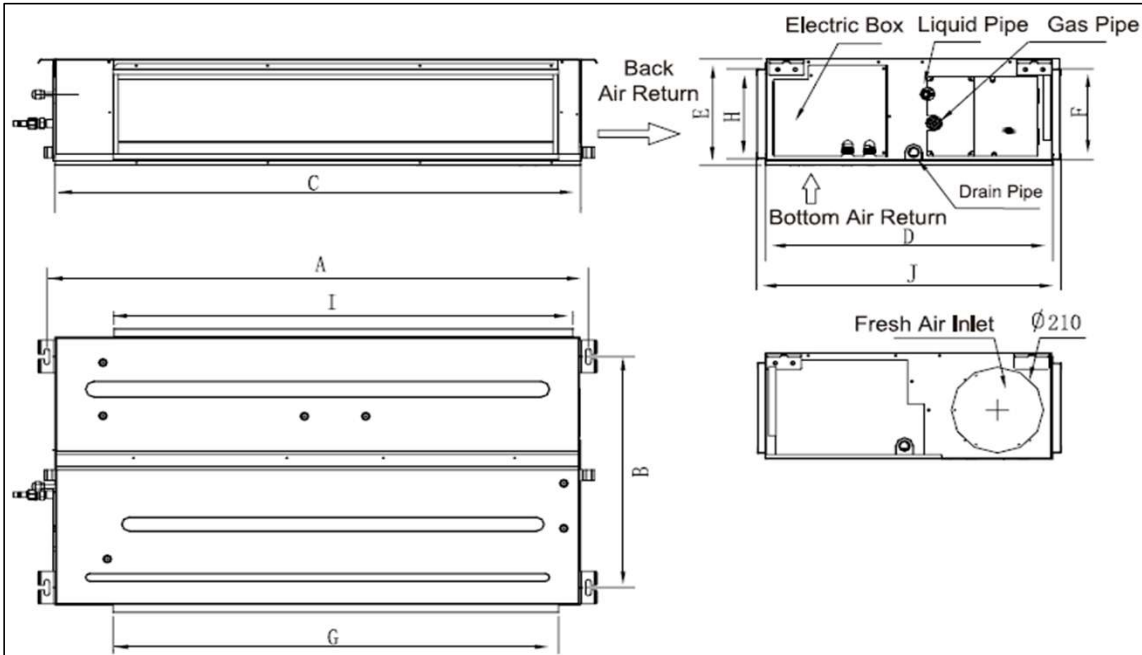

	mm	in
A	742	29.21
B	491	19.33
C	700	27.56
D	615	24.21
E	200	7.87
F	121	4.76
G	528	20.79
H	161	6.34
I	580	22.83

NOTE – Due to Lennox' ongoing commitment to quality, Specifications, Ratings and Dimensions subject to change without notice and without incurring liability. Improper installation, adjustment, alteration, service or maintenance can cause property damage or personal injury. Installation and service must be performed by a qualified installer and servicing agency. ©2014 Lennox Industries Inc.



SUBMITTAL DATA - INDOOR UNIT
VELD011N4U
VRF LOW STATIC FAN COIL EVAPORATOR

Job Name: _____
Location: _____
Schedule No.: _____
System Designation: _____

Engineer: _____
Architect: _____
Date: _____
For: ___ Reference ___ Approval ___ Review ___ Construction

FEATURES

- Auto Addressing installation
- Auto Restart
- Detachable Blower Motor
- Integrated Condensate Pump
- Built-in Electronic Expansion Valve
- LED Display
- Washable Filter
- Water Overflow Protection
- Anti-Freezing Protection

PRODUCT WARRANTY

All covered components - one year limited warranty

SPECIFICATIONS

PERFORMANCE

Cooling Capacity* (Btu/h)		10,918
Heating Capacity* (Btu/h)		12,283
Airflow (CFM)	High	325
	Medium	265
	Low	206
External Static Pressure	Pa	0 - 30
	in. WC	0 - 0.12
Sound Pressure Level (dBA)	H / M / L	32/30/27

ELECTRICAL DATA

Power Supply (V / Hz / Ph)	220-240/50/1 - 208-230/60/1
MOP (A)	6
Rated Current (A)	Cooling 0.2
	Heating 0.2

DIMENSIONS

Unit Dimensions (in)	Height	7 3/4
	Width	27 1/2
	Depth	24 1/4
Liquid Pipe Connection (in)		1/4
Gas Pipe Connection (in)		1/2
Shipping Weight (lb)		61.75
Net Weight (lb)		48.5

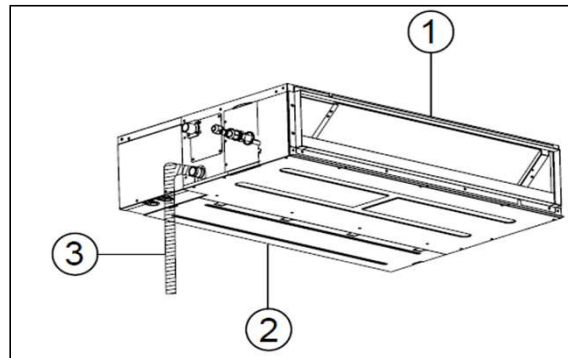
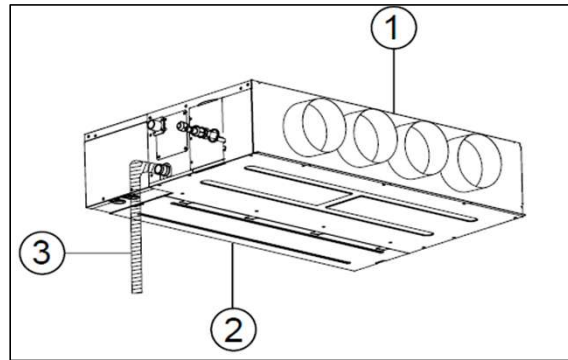

1. Air Outlet
2. Air-Return Opening
3. Drain Pipe

NOTES:

*Cooling and Heating Capacity data is rated at the following conditions:

Cooling: 80 °F DB / 67 °F WB Indoor, 95 °F DB Outdoor

Heating: 70 °F DB Indoor, 47 °F DB

NOTE – Due to Lennox' ongoing commitment to quality, Specifications, Ratings and Dimensions subject to change without notice and without incurring liability. Improper installation, adjustment, alteration, service or maintenance can cause property damage or personal injury. Installation and service must be performed by a qualified installer and servicing agency. ©2014 Lennox Industries Inc.



SUBMITTAL DATA - INDOOR UNIT
VELD011N4U
VRF LOW STATIC FAN COIL EVAPORATOR

DIMENSIONAL DRAWINGS

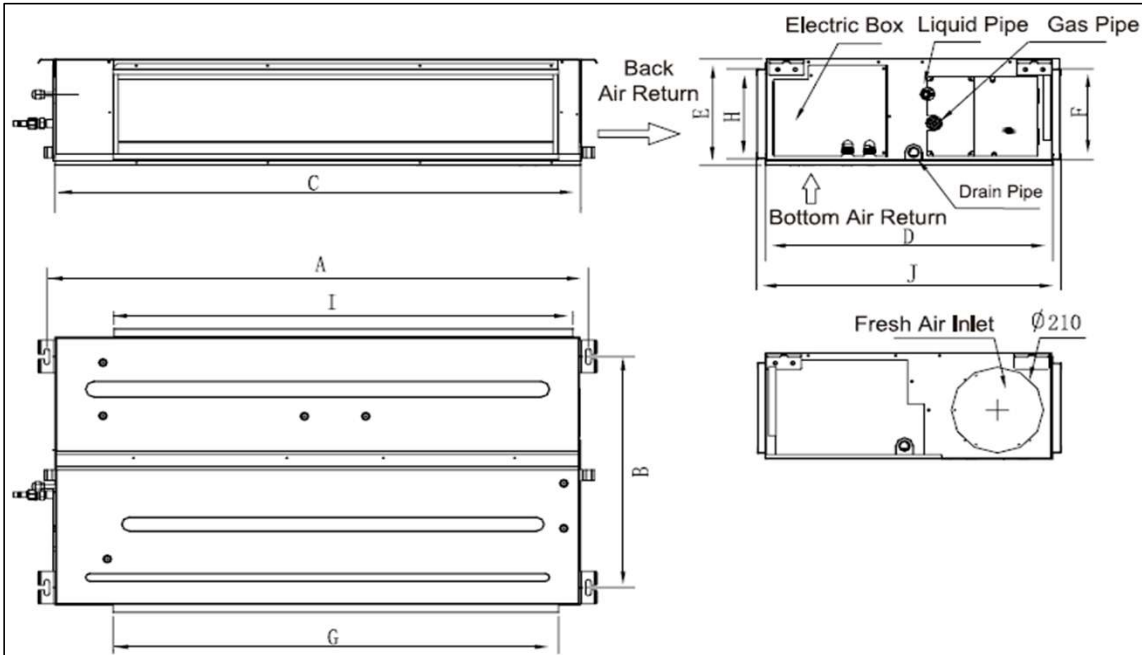

	mm	in
A	742	29.21
B	491	19.33
C	700	27.56
D	615	24.21
E	200	7.87
F	121	4.76
G	528	20.79
H	161	6.34
I	580	22.83

NOTE – Due to Lennox' ongoing commitment to quality, Specifications, Ratings and Dimensions subject to change without notice and without incurring liability. Improper installation, adjustment, alteration, service or maintenance can cause property damage or personal injury. Installation and service must be performed by a qualified installer and servicing agency. ©2014 Lennox Industries Inc.



SUBMITTAL DATA - INDOOR UNIT
VELD012N4U
VRF LOW STATIC FAN COIL EVAPORATOR

Job Name: _____
Location: _____
Schedule No.: _____
System Designation: _____

Engineer: _____
Architect: _____
Date: _____
For: ___ Reference ___ Approval ___ Review ___ Construction

FEATURES

- Auto Addressing installation
- Auto Restart
- Detachable Blower Motor
- Integrated Condensate Pump
- Built-in Electronic Expansion Valve
- LED Display
- Washable Filter
- Water Overflow Protection
- Anti-Freezing Protection

PRODUCT WARRANTY

All covered components - one year limited warranty

SPECIFICATIONS

PERFORMANCE

Cooling Capacity* (Btu/h)		12,283
Heating Capacity* (Btu/h)		13,648
Airflow (CFM)	High	325
	Medium	265
	Low	206
External Static Pressure	Pa	0 - 30
	in. WC	0 - 0.12
Sound Pressure Level (dBA)	H / M / L	32/30/27

ELECTRICAL DATA

Power Supply (V / Hz / Ph)	220-240/50/1 - 208-230/60/1
MOP (A)	6
Rated Current (A)	Cooling 0.2
	Heating 0.2

DIMENSIONS

Unit Dimensions (in)	Height	7 3/4
	Width	27 1/2
	Depth	24 1/4
Liquid Pipe Connection (in)		1/4
Gas Pipe Connection (in)		1/2
Shipping Weight (lb)		61.75
Net Weight (lb)		48.5

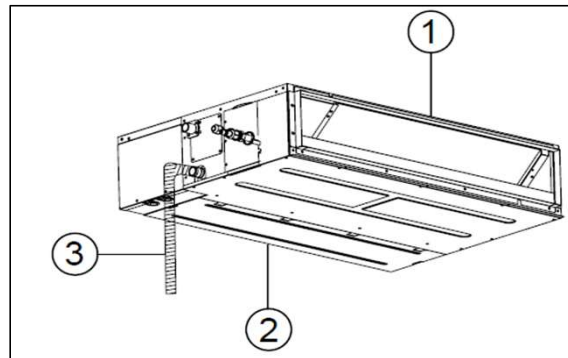
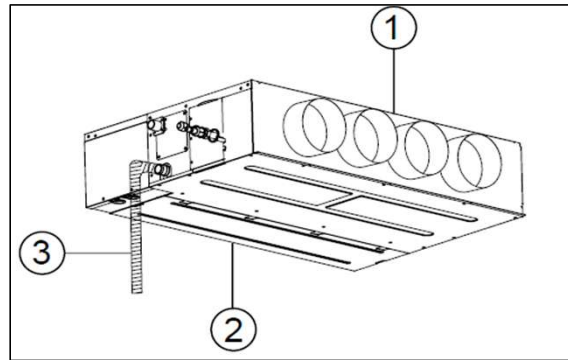

- 1. Air Outlet
- 2. Air-Return Opening
- 3. Drain Pipe

NOTES:

*Cooling and Heating Capacity data is rated at the following conditions:

Cooling: 80 °F DB / 67 °F WB Indoor, 95 °F DB Outdoor

Heating: 70 °F DB Indoor, 47 °F DB

NOTE – Due to Lennox' ongoing commitment to quality, Specifications, Ratings and Dimensions subject to change without notice and without incurring liability. Improper installation, adjustment, alteration, service or maintenance can cause property damage or personal injury. Installation and service must be performed by a qualified installer and servicing agency. ©2014 Lennox Industries Inc.



SUBMITTAL DATA - INDOOR UNIT
VELD012N4U
VRF LOW STATIC FAN COIL EVAPORATOR

DIMENSIONAL DRAWINGS

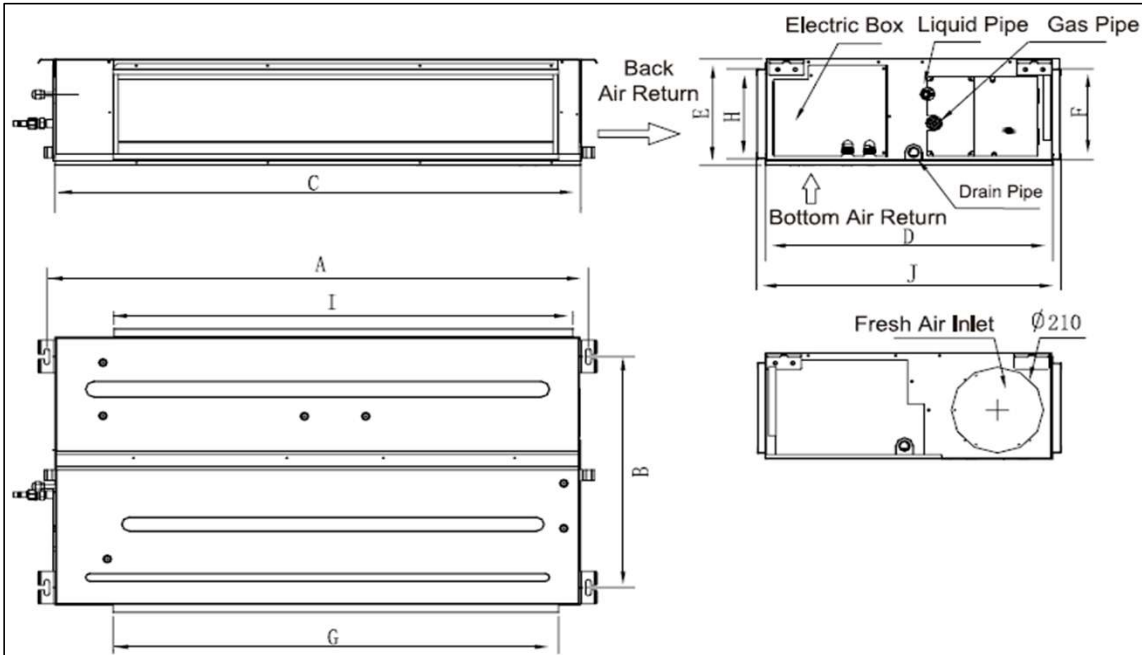

	mm	in
A	742	29.21
B	491	19.33
C	700	27.56
D	615	24.21
E	200	7.87
F	121	4.76
G	528	20.79
H	161	6.34
I	580	22.83

NOTE – Due to Lennox' ongoing commitment to quality, Specifications, Ratings and Dimensions subject to change without notice and without incurring liability. Improper installation, adjustment, alteration, service or maintenance can cause property damage or personal injury. Installation and service must be performed by a qualified installer and servicing agency. ©2014 Lennox Industries Inc.



SUBMITTAL DATA - INDOOR UNIT
VELD013N4U
VRF LOW STATIC FAN COIL EVAPORATOR

Job Name: _____
Location: _____
Schedule No.: _____
System Designation: _____

Engineer: _____
Architect: _____
Date: _____
For: ___ Reference ___ Approval ___ Review ___ Construction

FEATURES

- Auto Addressing installation
- Auto Restart
- Detachable Blower Motor
- Integrated Condensate Pump
- Built-in Electronic Expansion Valve
- LED Display
- Washable Filter
- Water Overflow Protection
- Anti-Freezing Protection

PRODUCT WARRANTY

All covered components - one year limited warranty

SPECIFICATIONS

PERFORMANCE

Cooling Capacity* (Btu/h)		13,648
Heating Capacity* (Btu/h)		15,354
Airflow (CFM)	High	410
	Medium	355
	Low	265
External Static Pressure	Pa	0 - 30
	in. WC	0 - 0.12
Sound Pressure Level (dBA)	H / M / L	33/31/28

ELECTRICAL DATA

Power Supply (V / Hz / Ph)	220-240/50/1 - 208-230/60/1
MOP (A)	6
Rated Current (A)	Cooling 0.3
	Heating 0.3

DIMENSIONS

Unit Dimensions (in)	Height	7 3/4
	Width	35 1/2
	Depth	24 1/4
Liquid Pipe Connection (in)		1/4
Gas Pipe Connection (in)		1/2
Shipping Weight (lb)		72.75
Net Weight (lb)		59.53

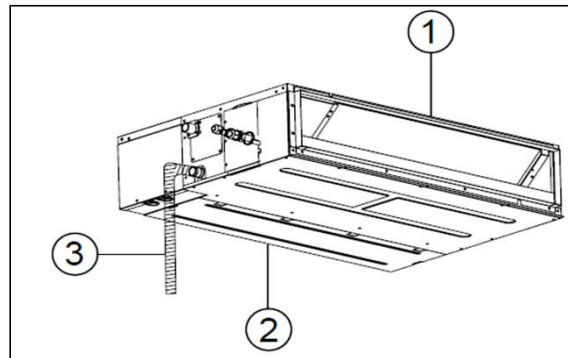
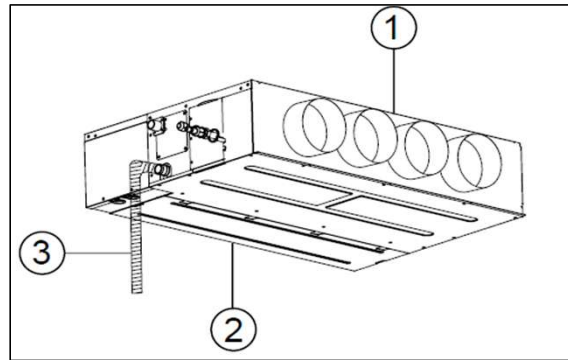

1. Air Outlet
2. Air-Return Opening
3. Drain Pipe

NOTES:

*Cooling and Heating Capacity data is rated at the following conditions:

Cooling: 80 °F DB / 67 °F WB Indoor, 95 °F DB Outdoor

Heating: 70 °F DB Indoor, 47 °F DB

NOTE – Due to Lennox' ongoing commitment to quality, Specifications, Ratings and Dimensions subject to change without notice and without incurring liability. Improper installation, adjustment, alteration, service or maintenance can cause property damage or personal injury. Installation and service must be performed by a qualified installer and servicing agency. ©2014 Lennox Industries Inc.



SUBMITTAL DATA - INDOOR UNIT
VELD013N4U
VRF LOW STATIC FAN COIL EVAPORATOR

DIMENSIONAL DRAWINGS

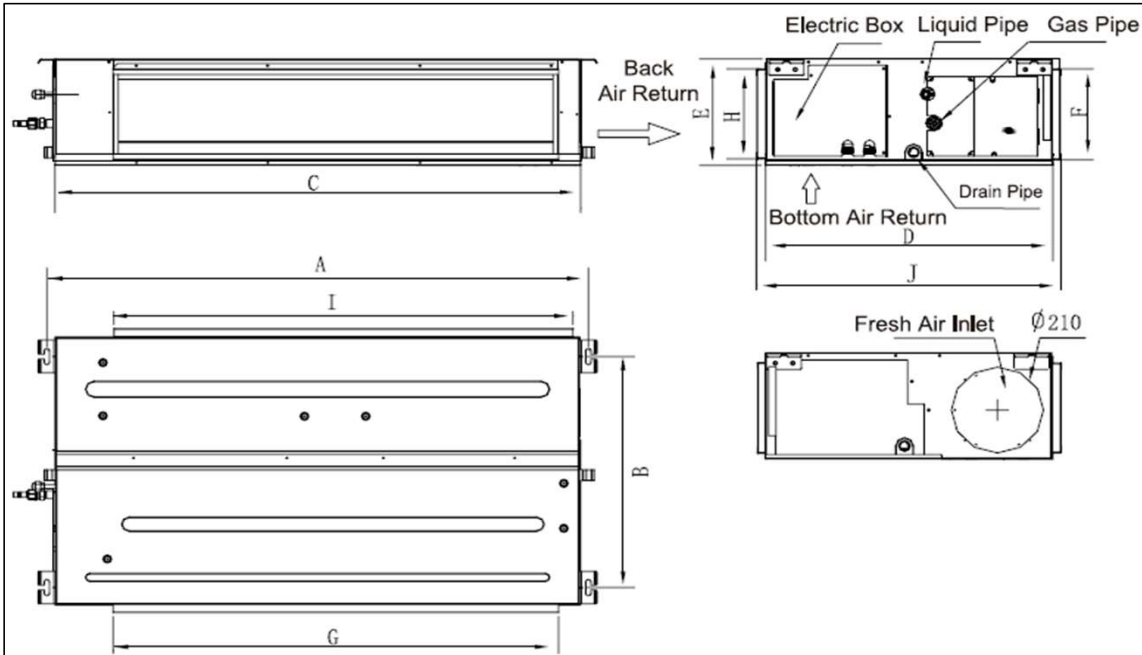

	mm	in
A	942	37.09
B	491	19.33
C	900	35.43
D	615	24.21
E	200	7.87
F	121	4.76
G	728	28.66
H	161	6.34
I	780	30.71

NOTE – Due to Lennox' ongoing commitment to quality, Specifications, Ratings and Dimensions subject to change without notice and without incurring liability. Improper installation, adjustment, alteration, service or maintenance can cause property damage or personal injury. Installation and service must be performed by a qualified installer and servicing agency. ©2014 Lennox Industries Inc.



SUBMITTAL DATA - INDOOR UNIT
VELD015N4U
VRF LOW STATIC FAN COIL EVAPORATOR

Job Name: _____
Location: _____
Schedule No.: _____
System Designation: _____

Engineer: _____
Architect: _____
Date: _____
For: ___ Reference ___ Approval ___ Review ___ Construction

FEATURES

- Auto Addressing installation
- Auto Restart
- Detachable Blower Motor
- Integrated Condensate Pump
- Built-in Electronic Expansion Valve
- LED Display
- Washable Filter
- Water Overflow Protection
- Anti-Freezing Protection

PRODUCT WARRANTY

All covered components - one year limited warranty

SPECIFICATIONS

PERFORMANCE

Cooling Capacity* (Btu/h)		15,354
Heating Capacity* (Btu/h)		17,060
Airflow (CFM)	High	410
	Medium	355
	Low	265
External Static Pressure	Pa	0 - 30
	in. WC	0 - 0.12
Sound Pressure Level (dBA)	H / M / L	33/31/28

ELECTRICAL DATA

Power Supply (V / Hz / Ph)	220-240/50/1 - 208-230/60/1	
MOP (A)		6
Rated Current (A)	Cooling	0.3
	Heating	0.3

DIMENSIONS

Unit Dimensions (in)	Height	7 3/4
	Width	35 1/2
	Depth	24 1/4
Liquid Pipe Connection (in)		1/4
Gas Pipe Connection (in)		1/2
Shipping Weight (lb)		72.75
Net Weight (lb)		59.53

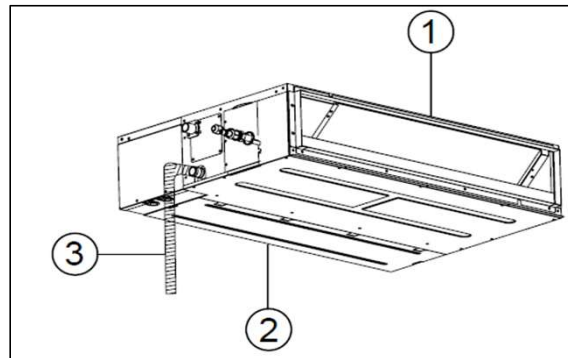
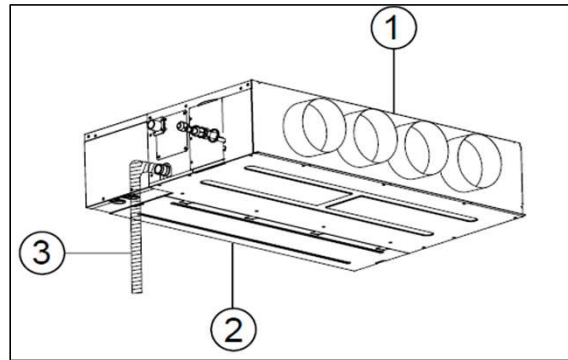

1. Air Outlet
2. Air-Return Opening
3. Drain Pipe

NOTES:

*Cooling and Heating Capacity data is rated at the following conditions:

Cooling: 80 °F DB / 67 °F WB Indoor, 95 °F DB Outdoor

Heating: 70 °F DB Indoor, 47 °F DB

NOTE – Due to Lennox' ongoing commitment to quality, Specifications, Ratings and Dimensions subject to change without notice and without incurring liability. Improper installation, adjustment, alteration, service or maintenance can cause property damage or personal injury. Installation and service must be performed by a qualified installer and servicing agency. ©2014 Lennox Industries Inc.



SUBMITTAL DATA - INDOOR UNIT
VELD015N4U
VRF LOW STATIC FAN COIL EVAPORATOR

DIMENSIONAL DRAWINGS

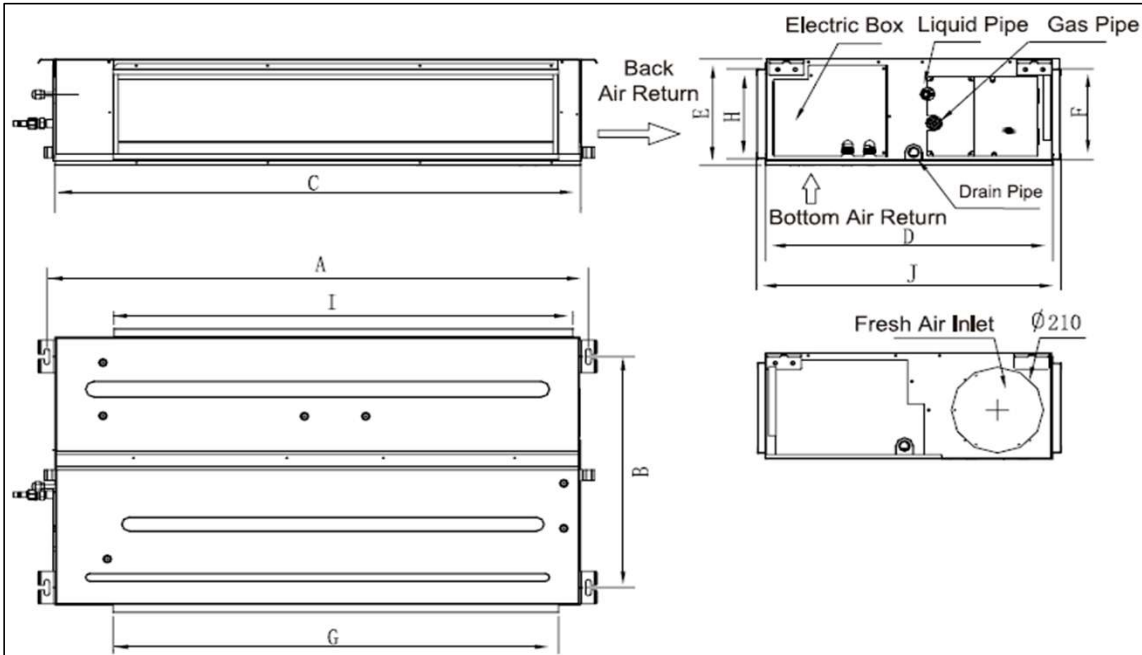

	mm	in
A	942	37.09
B	491	19.33
C	900	35.43
D	615	24.21
E	200	7.87
F	121	4.76
G	728	28.66
H	161	6.34
I	780	30.71

NOTE – Due to Lennox' ongoing commitment to quality, Specifications, Ratings and Dimensions subject to change without notice and without incurring liability. Improper installation, adjustment, alteration, service or maintenance can cause property damage or personal injury. Installation and service must be performed by a qualified installer and servicing agency. ©2014 Lennox Industries Inc.



SUBMITTAL DATA - INDOOR UNIT
VELD017N4U
VRF LOW STATIC FAN COIL EVAPORATOR

Job Name: _____
Location: _____
Schedule No.: _____
System Designation: _____

Engineer: _____
Architect: _____
Date: _____
For: ___ Reference ___ Approval ___ Review ___ Construction

FEATURES

- Auto Addressing installation
- Auto Restart
- Detachable Blower Motor
- Integrated Condensate Pump
- Built-in Electronic Expansion Valve
- LED Display
- Washable Filter
- Water Overflow Protection
- Anti-Freezing Protection

PRODUCT WARRANTY

All covered components - one year limited warranty

SPECIFICATIONS

PERFORMANCE

Cooling Capacity* (Btu/h)		17,060
Heating Capacity* (Btu/h)		19,107
Airflow (CFM)	High	410
	Medium	355
	Low	265
External Static Pressure	Pa	0 - 30
	in. WC	0 - 0.12
Sound Pressure Level (dBA)	H / M / L	33/31/28

ELECTRICAL DATA

Power Supply (V / Hz / Ph)	220-240/50/1 - 208-230/60/1
MOP (A)	6
Rated Current (A)	Cooling 0.3
	Heating 0.3

DIMENSIONS

Unit Dimensions (in)	Height	7 3/4
	Width	35 1/2
	Depth	24 1/4
Liquid Pipe Connection (in)		1/4
Gas Pipe Connection (in)		1/2
Shipping Weight (lb)		72.75
Net Weight (lb)		59.53

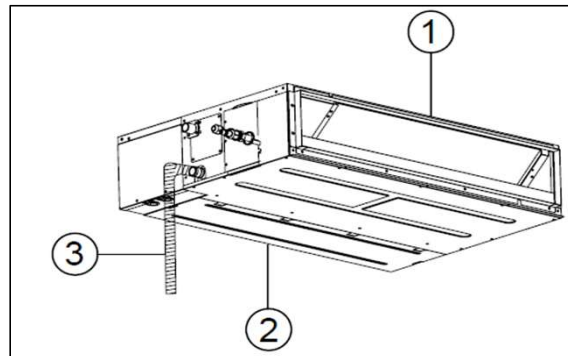
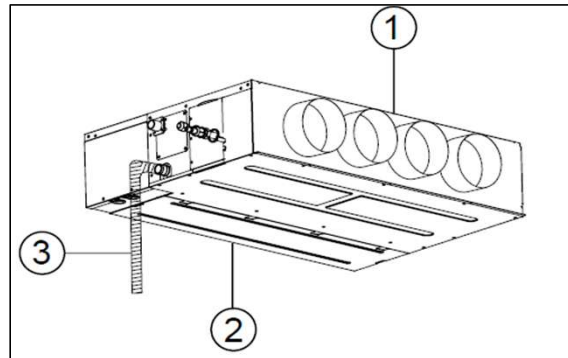

1. Air Outlet
2. Air-Return Opening
3. Drain Pipe

NOTES:

*Cooling and Heating Capacity data is rated at the following conditions:

Cooling: 80 °F DB / 67 °F WB Indoor, 95 °F DB Outdoor

Heating: 70 °F DB Indoor, 47 °F DB

NOTE – Due to Lennox' ongoing commitment to quality, Specifications, Ratings and Dimensions subject to change without notice and without incurring liability. Improper installation, adjustment, alteration, service or maintenance can cause property damage or personal injury. Installation and service must be performed by a qualified installer and servicing agency. ©2014 Lennox Industries Inc.



SUBMITTAL DATA - INDOOR UNIT
VELD017N4U
VRF LOW STATIC FAN COIL EVAPORATOR

DIMENSIONAL DRAWINGS

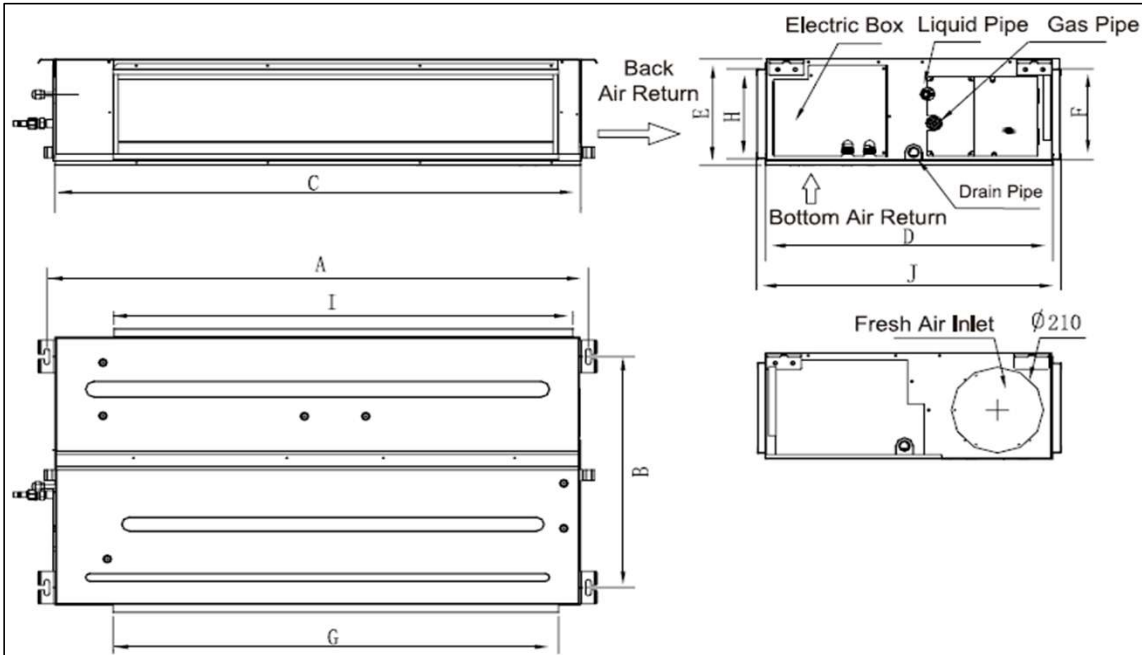

	mm	in
A	942	37.09
B	491	19.33
C	900	35.43
D	615	24.21
E	200	7.87
F	121	4.76
G	728	28.66
H	161	6.34
I	780	30.71

NOTE – Due to Lennox' ongoing commitment to quality, Specifications, Ratings and Dimensions subject to change without notice and without incurring liability. Improper installation, adjustment, alteration, service or maintenance can cause property damage or personal injury. Installation and service must be performed by a qualified installer and servicing agency. ©2014 Lennox Industries Inc.



SUBMITTAL DATA - INDOOR UNIT
VELD019N4U
VRF LOW STATIC FAN COIL EVAPORATOR

Job Name: _____
Location: _____
Schedule No.: _____
System Designation: _____

Engineer: _____
Architect: _____
Date: _____
For: ___ Reference ___ Approval ___ Review ___ Construction

FEATURES

- Auto Addressing installation
- Auto Restart
- Detachable Blower Motor
- Integrated Condensate Pump
- Built-in Electronic Expansion Valve
- LED Display
- Washable Filter
- Water Overflow Protection
- Anti-Freezing Protection

PRODUCT WARRANTY

All covered components - one year limited warranty

SPECIFICATIONS

PERFORMANCE

Cooling Capacity* (Btu/h)		19,107
Heating Capacity* (Btu/h)		21,496
Airflow (CFM)	High	590
	Medium	471
	Low	353
External Static Pressure	Pa	0 - 30
	in. WC	0 - 0.12
Sound Pressure Level (dBA)	H / M / L	35/33/30

ELECTRICAL DATA

Power Supply (V / Hz / Ph)	220-240/50/1 - 208-230/60/1
MOP (A)	6
Rated Current (A)	Cooling 0.5
	Heating 0.5

DIMENSIONS

Unit Dimensions (in)	Height	7 3/4
	Width	43 1/4
	Depth	24 1/4
Liquid Pipe Connection (in)		3/8
Gas Pipe Connection (in)		5/8
Shipping Weight (lb)		83.8
Net Weight (lb)		68.35

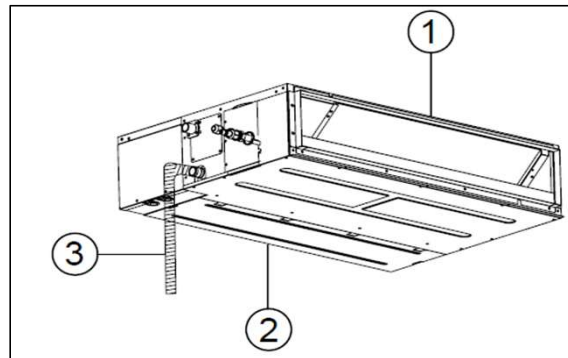
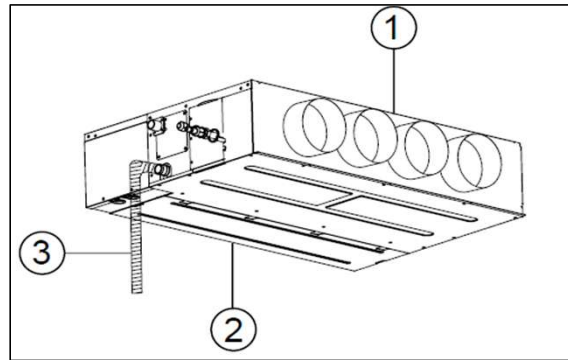

1. Air Outlet
2. Air-Return Opening
3. Drain Pipe

NOTES:

*Cooling and Heating Capacity data is rated at the following conditions:

Cooling: 80 °F DB / 67 °F WB Indoor, 95 °F DB Outdoor

Heating: 70 °F DB Indoor, 47 °F DB

NOTE – Due to Lennox’ ongoing commitment to quality, Specifications, Ratings and Dimensions subject to change without notice and without incurring liability. Improper installation, adjustment, alteration, service or maintenance can cause property damage or personal injury. Installation and service must be performed by a qualified installer and servicing agency. ©2014 Lennox Industries Inc.



SUBMITTAL DATA - INDOOR UNIT
VELD019N4U
VRF LOW STATIC FAN COIL EVAPORATOR

DIMENSIONAL DRAWINGS

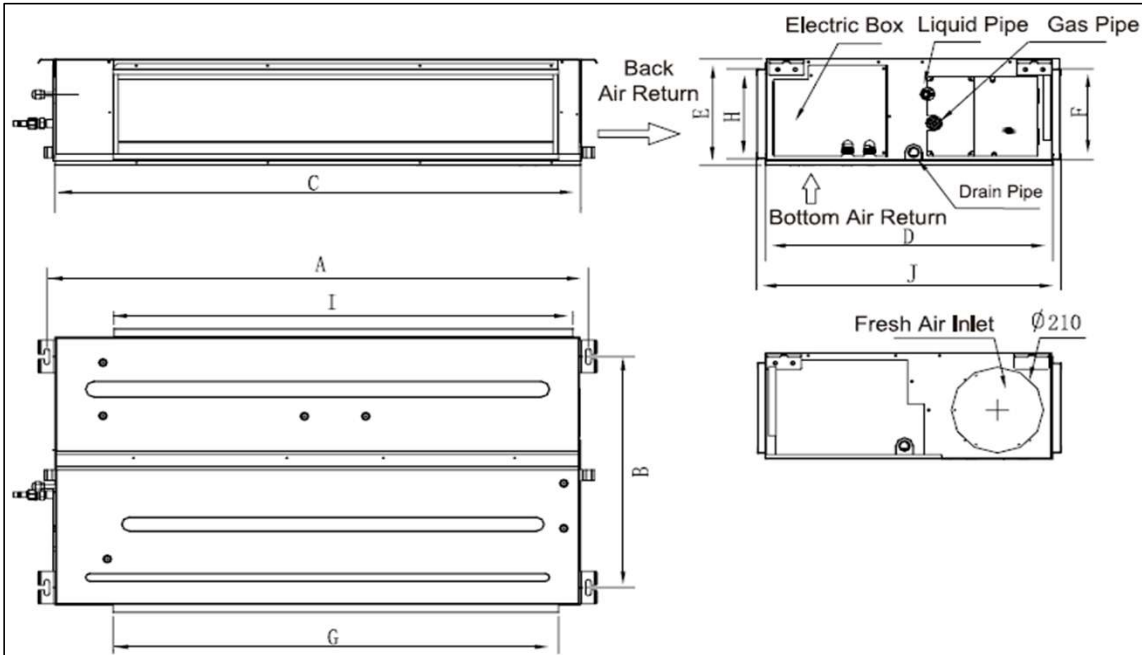

	mm	in
A	1142	44.96
B	491	19.33
C	1100	43.31
D	615	24.21
E	200	7.87
F	121	4.76
G	928	36.54
H	161	6.34
I	980	38.58

NOTE – Due to Lennox' ongoing commitment to quality, Specifications, Ratings and Dimensions subject to change without notice and without incurring liability. Improper installation, adjustment, alteration, service or maintenance can cause property damage or personal injury. Installation and service must be performed by a qualified installer and servicing agency. ©2014 Lennox Industries Inc.



SUBMITTAL DATA - INDOOR UNIT
VELD021N4U
VRF LOW STATIC FAN COIL EVAPORATOR

Job Name: _____
Location: _____
Schedule No.: _____
System Designation: _____

Engineer: _____
Architect: _____
Date: _____
For: ___ Reference ___ Approval ___ Review ___ Construction

FEATURES

- Auto Addressing installation
- Auto Restart
- Detachable Blower Motor
- Integrated Condensate Pump
- Built-in Electronic Expansion Valve
- LED Display
- Washable Filter
- Water Overflow Protection
- Anti-Freezing Protection

PRODUCT WARRANTY

All covered components - one year limited warranty

SPECIFICATIONS

PERFORMANCE

Cooling Capacity* (Btu/h)		21,496
Heating Capacity* (Btu/h)		24,225
Airflow (CFM)	High	590
	Medium	471
	Low	353
External Static Pressure	Pa	0 - 30
	in. WC	0 - 0.12
Sound Pressure Level (dBA)	H / M / L	35/33/30

ELECTRICAL DATA

Power Supply (V / Hz / Ph)	220-240/50/1 - 208-230/60/1
MOP (A)	6
Rated Current (A)	Cooling 0.5
	Heating 0.5

DIMENSIONS

Unit Dimensions (in)	Height	7 3/4
	Width	43 1/4
	Depth	24 1/4
Liquid Pipe Connection (in)		3/8
Gas Pipe Connection (in)		5/8
Shipping Weight (lb)		83.8
Net Weight (lb)		68.35

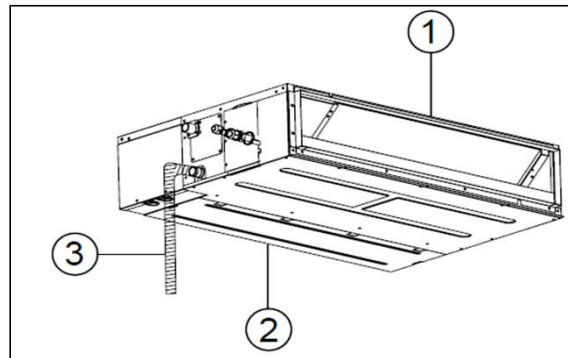
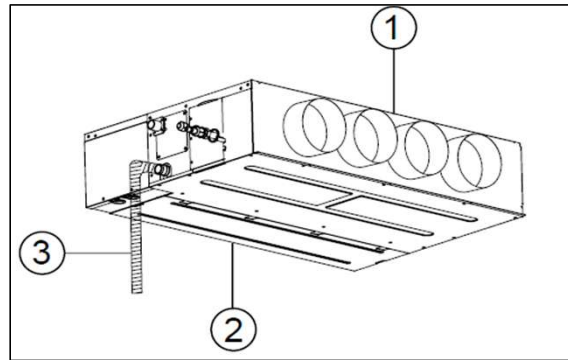

- 1. Air Outlet
- 2. Air-Return Opening
- 3. Drain Pipe

NOTES:

*Cooling and Heating Capacity data is rated at the following conditions:

Cooling: 80 °F DB / 67 °F WB Indoor, 95 °F DB Outdoor

Heating: 70 °F DB Indoor, 47 °F DB

NOTE – Due to Lennox' ongoing commitment to quality, Specifications, Ratings and Dimensions subject to change without notice and without incurring liability. Improper installation, adjustment, alteration, service or maintenance can cause property damage or personal injury. Installation and service must be performed by a qualified installer and servicing agency. ©2014 Lennox Industries Inc.



SUBMITTAL DATA - INDOOR UNIT
VELD021N4U
VRF LOW STATIC FAN COIL EVAPORATOR

DIMENSIONAL DRAWINGS

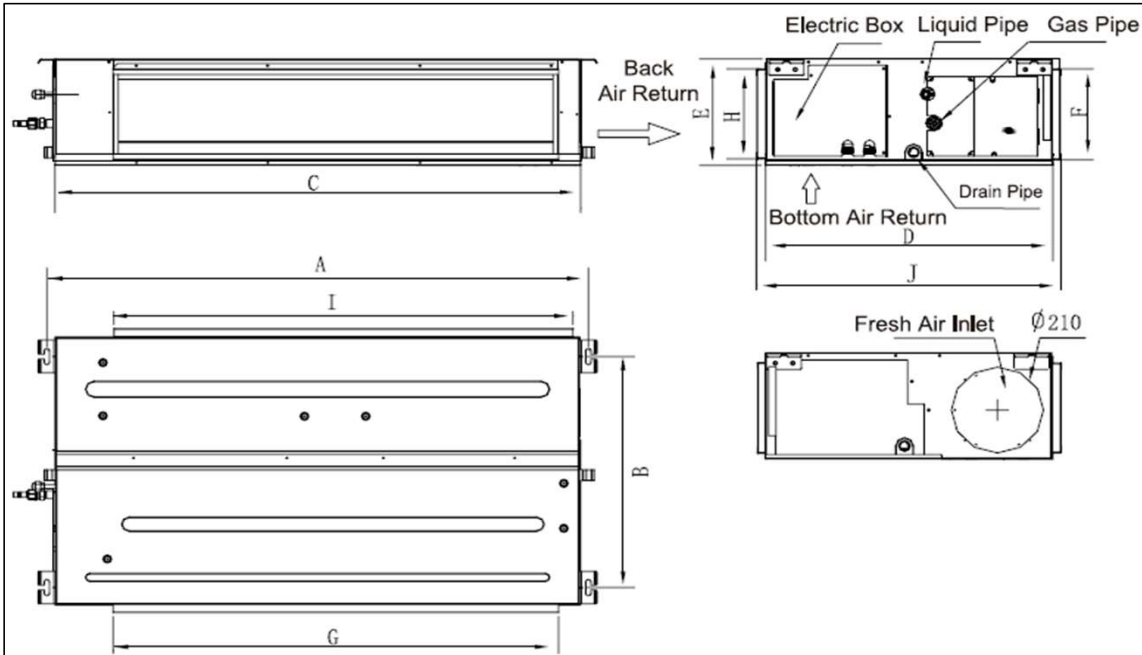

	mm	in
A	1142	44.96
B	491	19.33
C	1100	43.31
D	615	24.21
E	200	7.87
F	121	4.76
G	928	36.54
H	161	6.34
I	980	38.58

NOTE – Due to Lennox' ongoing commitment to quality, Specifications, Ratings and Dimensions subject to change without notice and without incurring liability. Improper installation, adjustment, alteration, service or maintenance can cause property damage or personal injury. Installation and service must be performed by a qualified installer and servicing agency. ©2014 Lennox Industries Inc.



SUBMITTAL DATA - INDOOR UNIT
VELD024N4U
VRF LOW STATIC FAN COIL EVAPORATOR

Job Name: _____
Location: _____
Schedule No.: _____
System Designation: _____

Engineer: _____
Architect: _____
Date: _____
For: ___ Reference ___ Approval ___ Review ___ Construction

FEATURES

- Auto Addressing installation
- Auto Restart
- Detachable Blower Motor
- Integrated Condensate Pump
- Built-in Electronic Expansion Valve
- LED Display
- Washable Filter
- Water Overflow Protection
- Anti-Freezing Protection

PRODUCT WARRANTY

All covered components - one year limited warranty

SPECIFICATIONS

PERFORMANCE

Cooling Capacity* (Btu/h)		24,225
Heating Capacity* (Btu/h)		27,296
Airflow (CFM)	High	590
	Medium	471
	Low	355
External Static Pressure	Pa	0 - 50
	in. WC	0 - 0.2
Sound Pressure Level (dBA)	H / M / L	35/33/30

ELECTRICAL DATA

Power Supply (V / Hz / Ph)	220-240/50/1 - 208-230/60/1
MOP (A)	6
Rated Current (A)	Cooling 0.5
	Heating 0.5

DIMENSIONS

Unit Dimensions (in)	Height	10 1/4
	Width	47 1/4
	Depth	25 3/4
Liquid Pipe Connection (in)		3/8
Gas Pipe Connection (in)		5/8
Shipping Weight (lb)		103.6
Net Weight (lb)		88.2

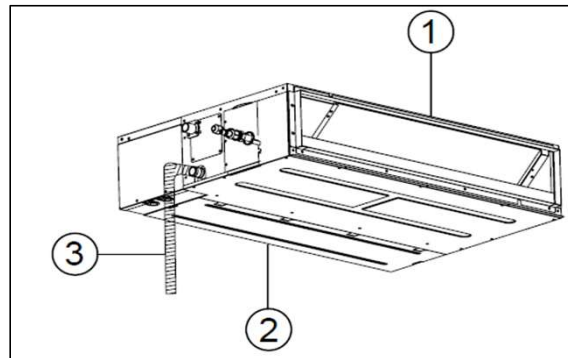
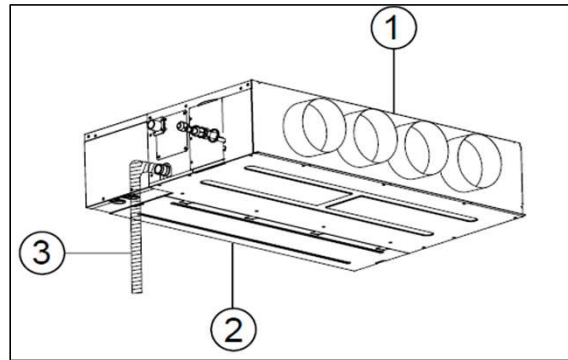

1. Air Outlet
2. Air-Return Opening
3. Drain Pipe

NOTES:

*Cooling and Heating Capacity data is rated at the following conditions:

Cooling: 80 °F DB / 67 °F WB Indoor, 95 °F DB Outdoor

Heating: 70 °F DB Indoor, 47 °F DB

NOTE – Due to Lennox' ongoing commitment to quality, Specifications, Ratings and Dimensions subject to change without notice and without incurring liability. Improper installation, adjustment, alteration, service or maintenance can cause property damage or personal injury. Installation and service must be performed by a qualified installer and servicing agency. ©2014 Lennox Industries Inc.



SUBMITTAL DATA - INDOOR UNIT
VELD024N4U
VRF LOW STATIC FAN COIL EVAPORATOR

DIMENSIONAL DRAWINGS

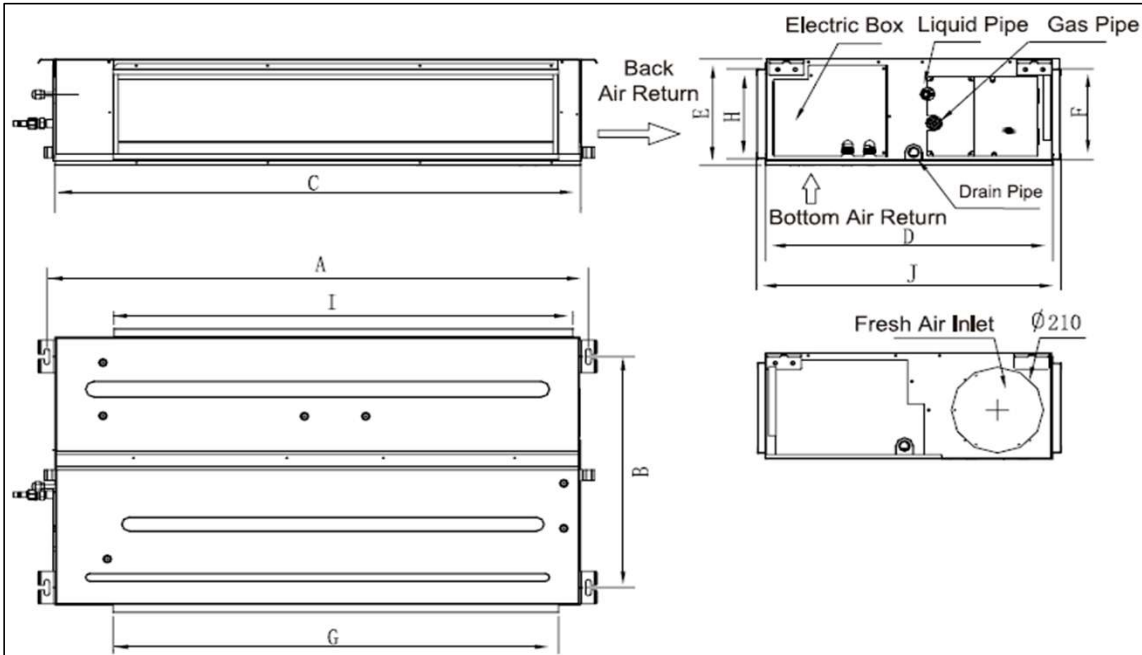

	mm	in
A	1236	48.66
B	565	22.24
C	1200	47.24
D	655	25.79
E	260	10.24
F	222	8.74
G	1016	40.00
H	220	8.66
I	1050	41.34
J	695	27.36

NOTE – Due to Lennox' ongoing commitment to quality, Specifications, Ratings and Dimensions subject to change without notice and without incurring liability. Improper installation, adjustment, alteration, service or maintenance can cause property damage or personal injury. Installation and service must be performed by a qualified installer and servicing agency. ©2014 Lennox Industries Inc.



SUBMITTAL DATA - INDOOR UNIT
VELD027N4U
VRF LOW STATIC FAN COIL EVAPORATOR

Job Name: _____
Location: _____
Schedule No.: _____
System Designation: _____

Engineer: _____
Architect: _____
Date: _____
For: ___ Reference ___ Approval ___ Review ___ Construction

FEATURES

- Auto Addressing installation
- Auto Restart
- Detachable Blower Motor
- Integrated Condensate Pump
- Built-in Electronic Expansion Valve
- LED Display
- Washable Filter
- Water Overflow Protection
- Anti-Freezing Protection

PRODUCT WARRANTY

All covered components - one year limited warranty

SPECIFICATIONS

PERFORMANCE

Cooling Capacity* (Btu/h)		27,296
Heating Capacity* (Btu/h)		30,708
Airflow (CFM)	High	650
	Medium	590
	Low	471
External Static Pressure	Pa	0 - 50
	in. WC	0 - 0.2
Sound Pressure Level (dBA)	H / M / L	36/34/31

ELECTRICAL DATA

Power Supply (V / Hz / Ph)	220-240/50/1 - 208-230/60/1
MOP (A)	6
Rated Current (A)	Cooling 0.7
	Heating 0.7

DIMENSIONS

Unit Dimensions (in)	Height	10 1/4
	Width	47 1/4
	Depth	25 3/4
Liquid Pipe Connection (in)		3/8
Gas Pipe Connection (in)		5/8
Shipping Weight (lb)		103.6
Net Weight (lb)		88.2

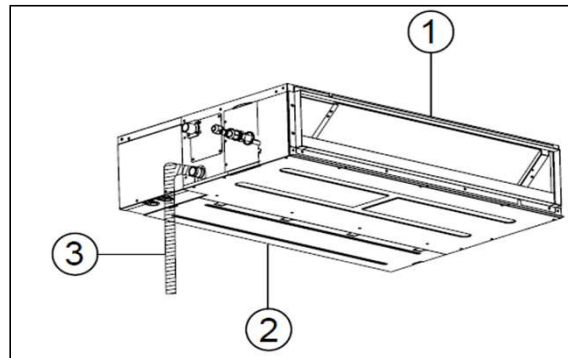
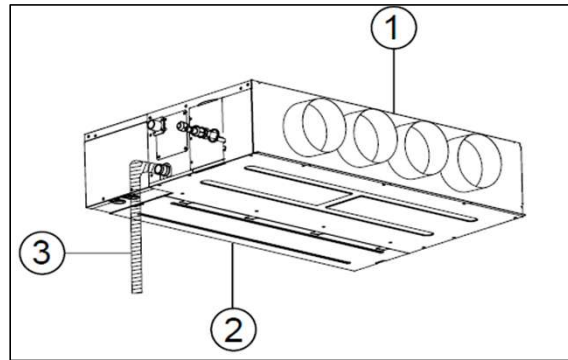

1. Air Outlet
2. Air-Return Opening
3. Drain Pipe

NOTES:

*Cooling and Heating Capacity data is rated at the following conditions:

Cooling: 80 °F DB / 67 °F WB Indoor, 95 °F DB Outdoor

Heating: 70 °F DB Indoor, 47 °F DB

NOTE – Due to Lennox' ongoing commitment to quality, Specifications, Ratings and Dimensions subject to change without notice and without incurring liability. Improper installation, adjustment, alteration, service or maintenance can cause property damage or personal injury. Installation and service must be performed by a qualified installer and servicing agency. ©2014 Lennox Industries Inc.



SUBMITTAL DATA - INDOOR UNIT
VELD027N4U
VRF LOW STATIC FAN COIL EVAPORATOR

DIMENSIONAL DRAWINGS

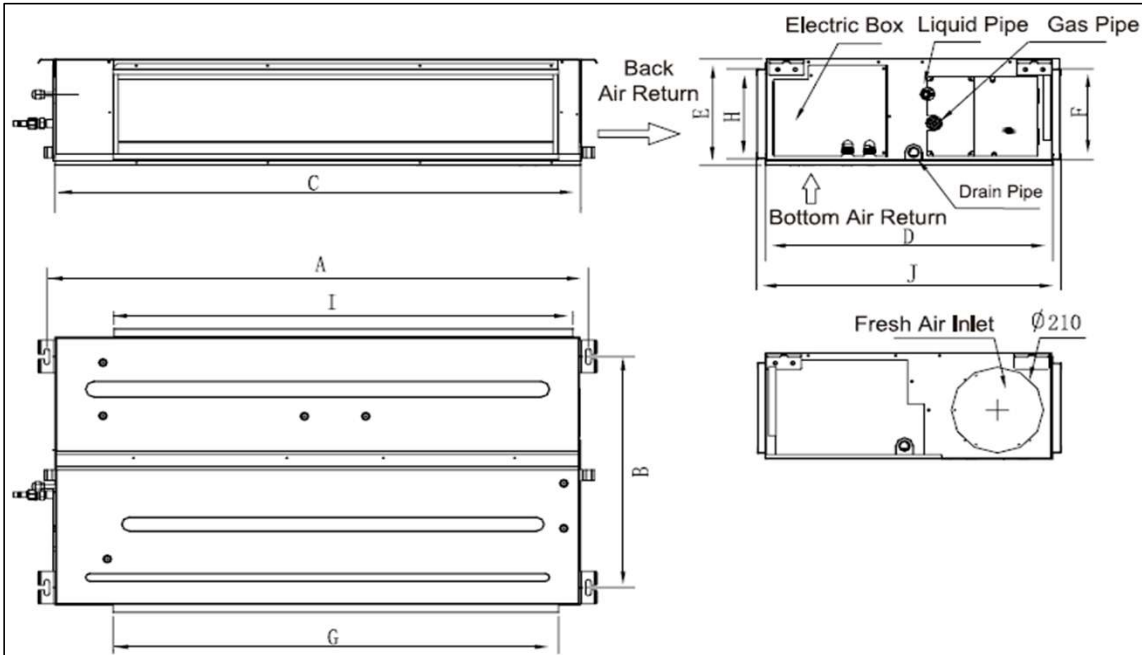

	mm	in
A	1236	48.66
B	565	22.24
C	1200	47.24
D	655	25.79
E	260	10.24
F	222	8.74
G	1016	40.00
H	220	8.66
I	1050	41.34
J	695	27.36

NOTE – Due to Lennox' ongoing commitment to quality, Specifications, Ratings and Dimensions subject to change without notice and without incurring liability. Improper installation, adjustment, alteration, service or maintenance can cause property damage or personal injury. Installation and service must be performed by a qualified installer and servicing agency. ©2014 Lennox Industries Inc.



SUBMITTAL DATA - INDOOR UNIT
VELD031N4U
VRF LOW STATIC FAN COIL EVAPORATOR

Job Name: _____
Location: _____
Schedule No.: _____
System Designation: _____

Engineer: _____
Architect: _____
Date: _____
For: ___ Reference ___ Approval ___ Review ___ Construction

FEATURES

- Auto Addressing installation
- Auto Restart
- Detachable Blower Motor
- Integrated Condensate Pump
- Built-in Electronic Expansion Valve
- LED Display
- Washable Filter
- Water Overflow Protection
- Anti-Freezing Protection

PRODUCT WARRANTY

All covered components - one year limited warranty

SPECIFICATIONS

PERFORMANCE

Cooling Capacity* (Btu/h)		30,708
Heating Capacity* (Btu/h)		34,120
Airflow (CFM)	High	885
	Medium	736
	Low	600
External Static Pressure	Pa	0 - 50
	in. WC	0 - 0.2
Sound Pressure Level (dBA)	H / M / L	40/36/32

ELECTRICAL DATA

Power Supply (V / Hz / Ph)	220-240/50/1 - 208-230/60/1
MOP (A)	6
Rated Current (A)	Cooling 1.0
	Heating 1.0

DIMENSIONS

Unit Dimensions (in)	Height	10 1/4
	Width	52 3/4
	Depth	25 3/4
Liquid Pipe Connection (in)		3/8
Gas Pipe Connection (in)		5/8
Shipping Weight (lb)		121.28
Net Weight (lb)		101.43

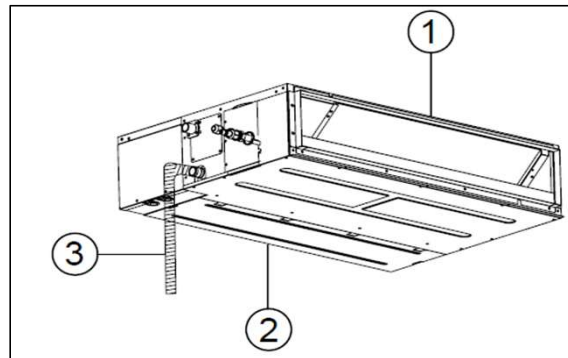
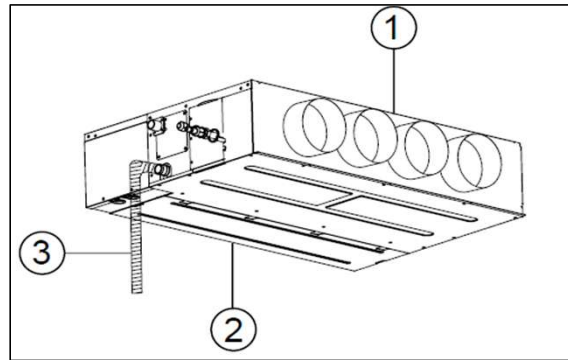

1. Air Outlet
2. Air-Return Opening
3. Drain Pipe

NOTES:

*Cooling and Heating Capacity data is rated at the following conditions:

Cooling: 80 °F DB / 67 °F WB Indoor, 95 °F DB Outdoor

Heating: 70 °F DB Indoor, 47 °F DB

NOTE – Due to Lennox' ongoing commitment to quality, Specifications, Ratings and Dimensions subject to change without notice and without incurring liability. Improper installation, adjustment, alteration, service or maintenance can cause property damage or personal injury. Installation and service must be performed by a qualified installer and servicing agency. ©2014 Lennox Industries Inc.



SUBMITTAL DATA - INDOOR UNIT
VELD031N4U
VRF LOW STATIC FAN COIL EVAPORATOR

DIMENSIONAL DRAWINGS

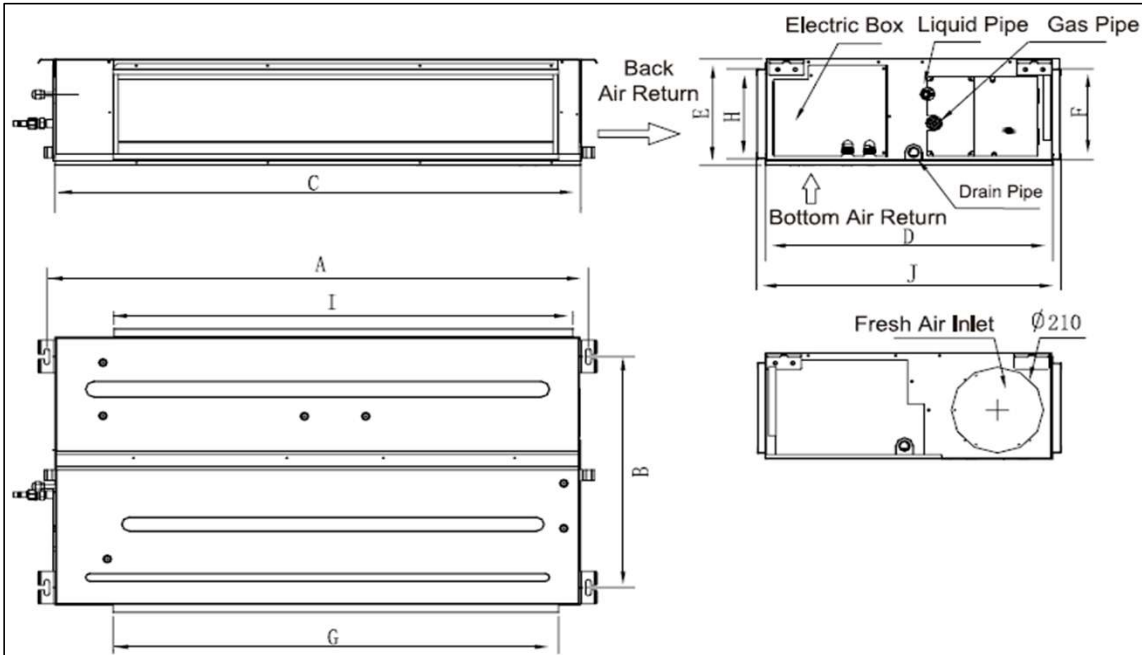

	mm	in
A	1379	54.29
B	565	22.24
C	1340	52.76
D	655	25.79
E	260	10.24
F	207	8.15
G	1153	45.39
H	220	8.66
I	1188	46.77
J	716	28.19

NOTE – Due to Lennox' ongoing commitment to quality, Specifications, Ratings and Dimensions subject to change without notice and without incurring liability. Improper installation, adjustment, alteration, service or maintenance can cause property damage or personal injury. Installation and service must be performed by a qualified installer and servicing agency. ©2014 Lennox Industries Inc.



SUBMITTAL DATA - INDOOR UNIT
VELD034N4U
VRF LOW STATIC FAN COIL EVAPORATOR

Job Name: _____
Location: _____
Schedule No.: _____
System Designation: _____

Engineer: _____
Architect: _____
Date: _____
For: ___ Reference ___ Approval ___ Review ___ Construction

FEATURES

- Auto Addressing installation
- Auto Restart
- Detachable Blower Motor
- Integrated Condensate Pump
- Built-in Electronic Expansion Valve
- LED Display
- Washable Filter
- Water Overflow Protection
- Anti-Freezing Protection

PRODUCT WARRANTY

All covered components - one year limited warranty

SPECIFICATIONS

PERFORMANCE

Cooling Capacity* (Btu/h)		34,120
Heating Capacity* (Btu/h)		38,214
Airflow (CFM)	High	885
	Medium	736
	Low	599
External Static Pressure	Pa	0 - 50
	in. WC	0 - 0.2
Sound Pressure Level (dBA)	H / M / L	40/36/32

ELECTRICAL DATA

Power Supply (V / Hz / Ph)	220-240/50/1 - 208-230/60/1
MOP (A)	6
Rated Current (A)	Cooling 1
	Heating 1

DIMENSIONS

Unit Dimensions (in)	Height	10 1/4
	Width	52 3/4
	Depth	25 3/4
Liquid Pipe Connection (in)		3/8
Gas Pipe Connection (in)		5/8
Shipping Weight (lb)		121.3
Net Weight (lb)		101.4

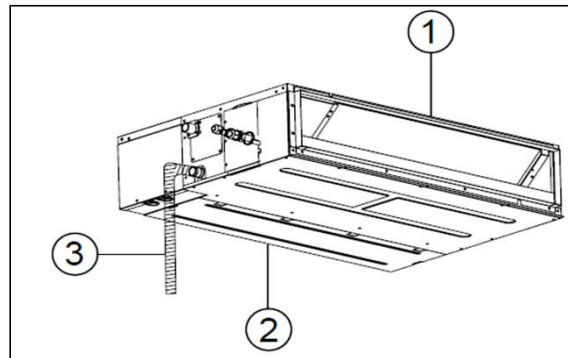
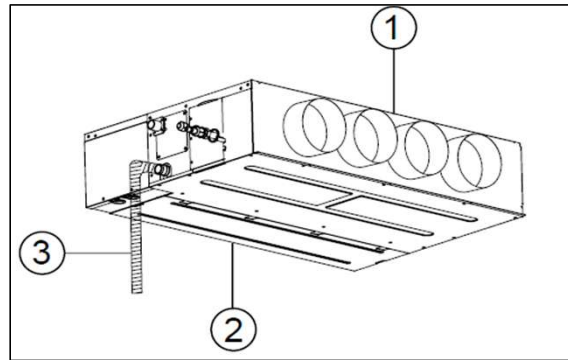

1. Air Outlet
2. Air-Return Opening
3. Drain Pipe

NOTES:

*Cooling and Heating Capacity data is rated at the following conditions:

Cooling: 80 °F DB / 67 °F WB Indoor, 95 °F DB Outdoor

Heating: 70 °F DB Indoor, 47 °F DB

NOTE – Due to Lennox' ongoing commitment to quality, Specifications, Ratings and Dimensions subject to change without notice and without incurring liability. Improper installation, adjustment, alteration, service or maintenance can cause property damage or personal injury. Installation and service must be performed by a qualified installer and servicing agency. ©2014 Lennox Industries Inc.



SUBMITTAL DATA - INDOOR UNIT
VELD034N4U
VRF LOW STATIC FAN COIL EVAPORATOR

DIMENSIONAL DRAWINGS

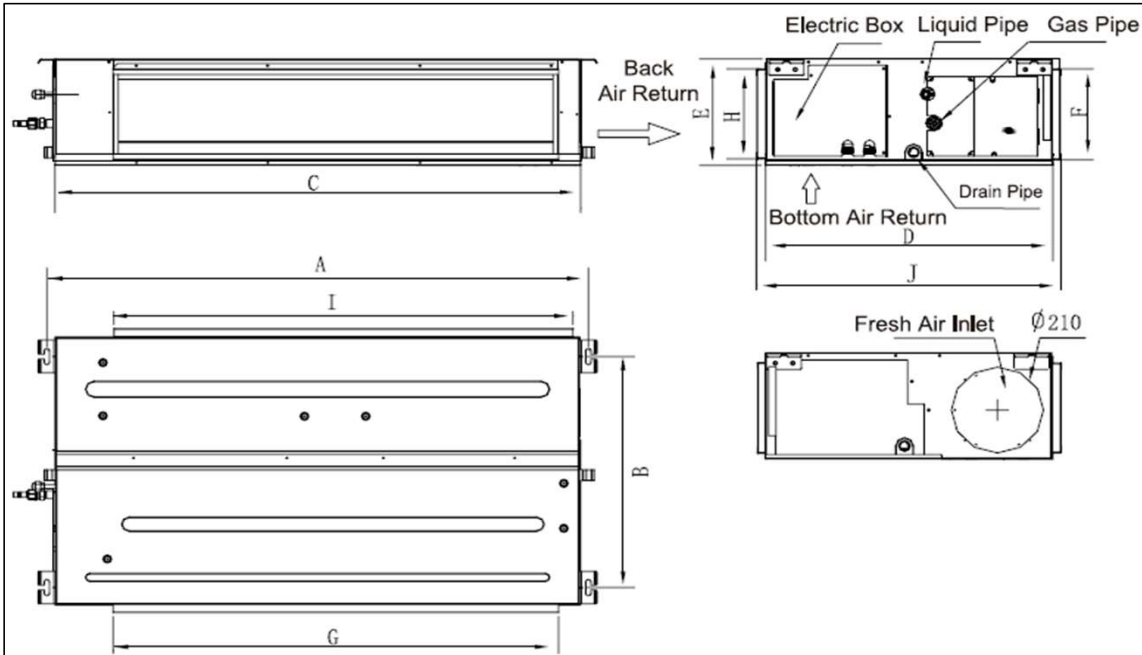

	mm	in
A	1379	54.29
B	565	22.24
C	1340	52.76
D	655	25.79
E	260	10.24
F	207	8.15
G	1153	45.39
H	220	8.66
I	1188	46.77
J	716	28.19

NOTE – Due to Lennox' ongoing commitment to quality, Specifications, Ratings and Dimensions subject to change without notice and without incurring liability. Improper installation, adjustment, alteration, service or maintenance can cause property damage or personal injury. Installation and service must be performed by a qualified installer and servicing agency. ©2014 Lennox Industries Inc.



SUBMITTAL DATA - INDOOR UNIT
VELD038N4U
VRF LOW STATIC FAN COIL EVAPORATOR

Job Name: _____
Location: _____
Schedule No.: _____
System Designation: _____

Engineer: _____
Architect: _____
Date: _____
For: ___ Reference ___ Approval ___ Review ___ Construction

FEATURES

- Auto Addressing installation
- Auto Restart
- Detachable Blower Motor
- Integrated Condensate Pump
- Built-in Electronic Expansion Valve
- LED Display
- Washable Filter
- Water Overflow Protection
- Anti-Freezing Protection

PRODUCT WARRANTY

All covered components - one year limited warranty

SPECIFICATIONS

PERFORMANCE

Cooling Capacity* (Btu/h)		38,214
Heating Capacity* (Btu/h)		42,650
Airflow (CFM)	High	1000
	Medium	885
	Low	650
External Static Pressure	Pa	0 - 50
	in. WC	0 - 0.2
Sound Pressure Level (dBA)	H / M / L	40/36/32

ELECTRICAL DATA

Power Supply (V / Hz / Ph)	220-240/50/1 - 208-230/60/1
MOP (A)	6
Rated Current (A)	Cooling 1
	Heating 1

DIMENSIONS

Unit Dimensions (in)	Height	10 1/4
	Width	52 3/4
	Depth	25 3/4
Liquid Pipe Connection (in)		3/8
Gas Pipe Connection (in)		5/8
Shipping Weight (lb)		121.3
Net Weight (lb)		101.4

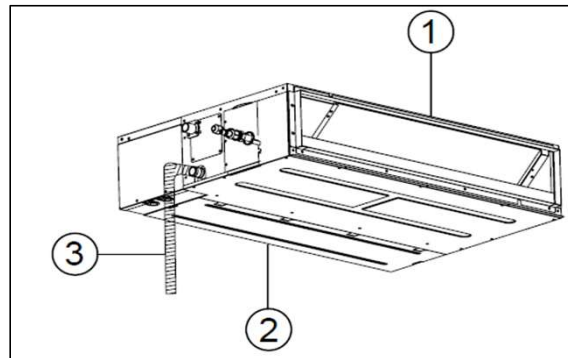
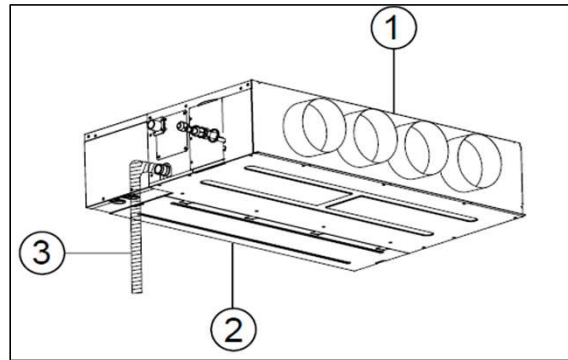

1. Air Outlet
2. Air-Return Opening
3. Drain Pipe

NOTES:

*Cooling and Heating Capacity data is rated at the following conditions:

Cooling: 80 °F DB / 67 °F WB Indoor, 95 °F DB Outdoor

Heating: 70 °F DB Indoor, 47 °F DB

NOTE – Due to Lennox' ongoing commitment to quality, Specifications, Ratings and Dimensions subject to change without notice and without incurring liability. Improper installation, adjustment, alteration, service or maintenance can cause property damage or personal injury. Installation and service must be performed by a qualified installer and servicing agency. ©2014 Lennox Industries Inc.



SUBMITTAL DATA - INDOOR UNIT
VELD038N4U
VRF LOW STATIC FAN COIL EVAPORATOR

DIMENSIONAL DRAWINGS

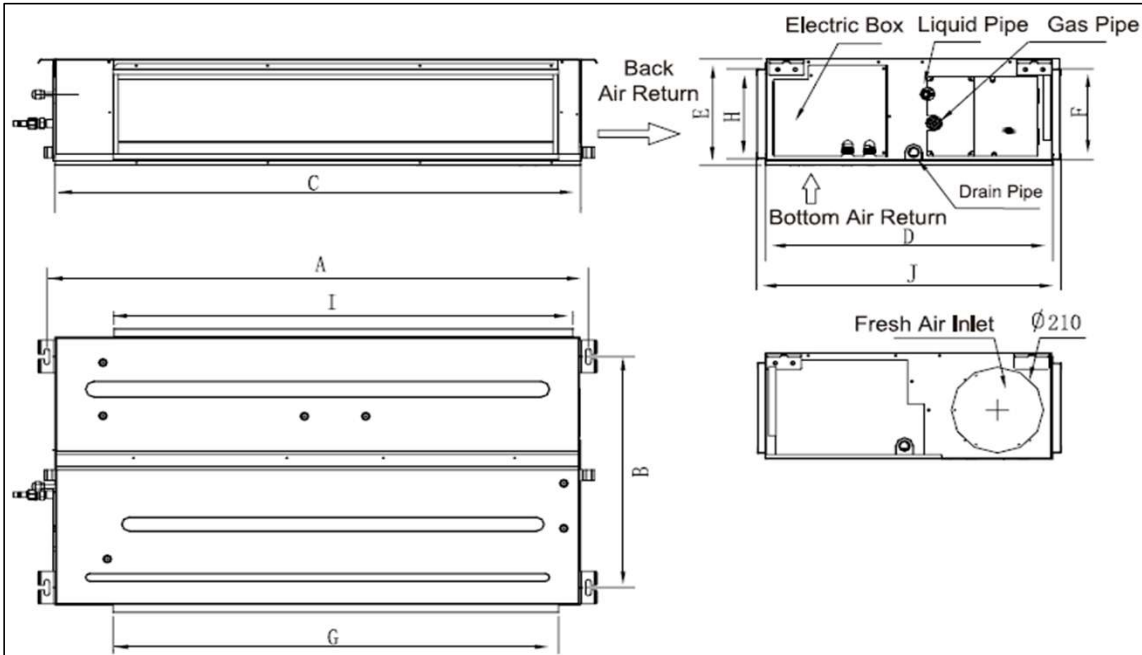

	mm	in
A	1379	54.29
B	565	22.24
C	1340	52.76
D	655	25.79
E	260	10.24
F	207	8.15
G	1153	45.39
H	220	8.66
I	1188	46.77
J	716	28.19

NOTE – Due to Lennox' ongoing commitment to quality, Specifications, Ratings and Dimensions subject to change without notice and without incurring liability. Improper installation, adjustment, alteration, service or maintenance can cause property damage or personal injury. Installation and service must be performed by a qualified installer and servicing agency. ©2014 Lennox Industries Inc.



SUBMITTAL DATA - INDOOR UNIT
VELD042N4U
VRF LOW STATIC FAN COIL EVAPORATOR

Job Name: _____
Location: _____
Schedule No.: _____
System Designation: _____

Engineer: _____
Architect: _____
Date: _____
For: ___ Reference ___ Approval ___ Review ___ Construction

FEATURES

- Auto Addressing installation
- Auto Restart
- Detachable Blower Motor
- Integrated Condensate Pump
- Built-in Electronic Expansion Valve
- LED Display
- Washable Filter
- Water Overflow Protection
- Anti-Freezing Protection

PRODUCT WARRANTY

All covered components - one year limited warranty

SPECIFICATIONS

PERFORMANCE

Cooling Capacity* (Btu/h)		42,650
Heating Capacity* (Btu/h)		47,768
Airflow (CFM)	High	1175
	Medium	885
	Low	677
External Static Pressure	Pa	0 - 50
	in. WC	0 - 0.2
Sound Pressure Level (dBA)	H / M / L	42/40/37

ELECTRICAL DATA

Power Supply (V / Hz / Ph)	220-240/50/1 - 208-230/60/1
MOP (A)	6
Rated Current (A)	Cooling 1.1
	Heating 1.1

DIMENSIONS

Unit Dimensions (in)	Height	10 1/4
	Width	52 3/4
	Depth	25 3/4
Liquid Pipe Connection (in)		3/8
Gas Pipe Connection (in)		5/8
Shipping Weight (lb)		123.5
Net Weight (lb)		103.6

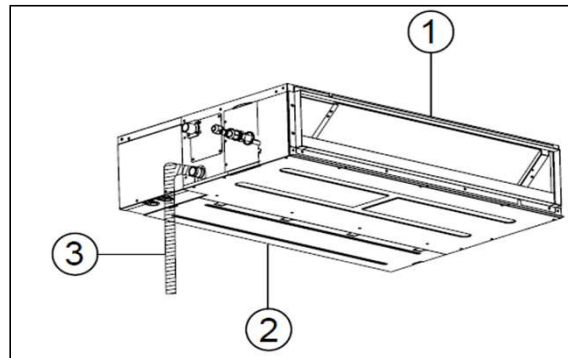
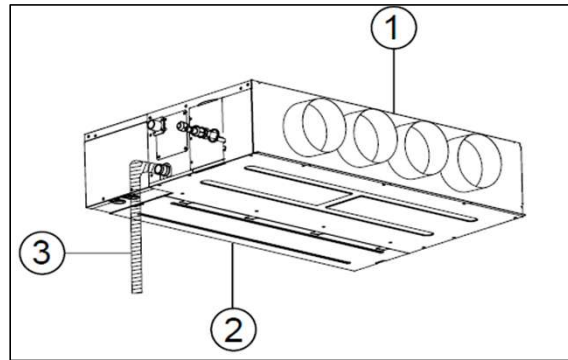

- 1. Air Outlet
- 2. Air-Return Opening
- 3. Drain Pipe

NOTES:

*Cooling and Heating Capacity data is rated at the following conditions:

Cooling: 80 °F DB / 67 °F WB Indoor, 95 °F DB Outdoor

Heating: 70 °F DB Indoor, 47 °F DB

NOTE – Due to Lennox’ ongoing commitment to quality, Specifications, Ratings and Dimensions subject to change without notice and without incurring liability. Improper installation, adjustment, alteration, service or maintenance can cause property damage or personal injury. Installation and service must be performed by a qualified installer and servicing agency. ©2014 Lennox Industries Inc.



SUBMITTAL DATA - INDOOR UNIT
VELD042N4U
VRF LOW STATIC FAN COIL EVAPORATOR

DIMENSIONAL DRAWINGS

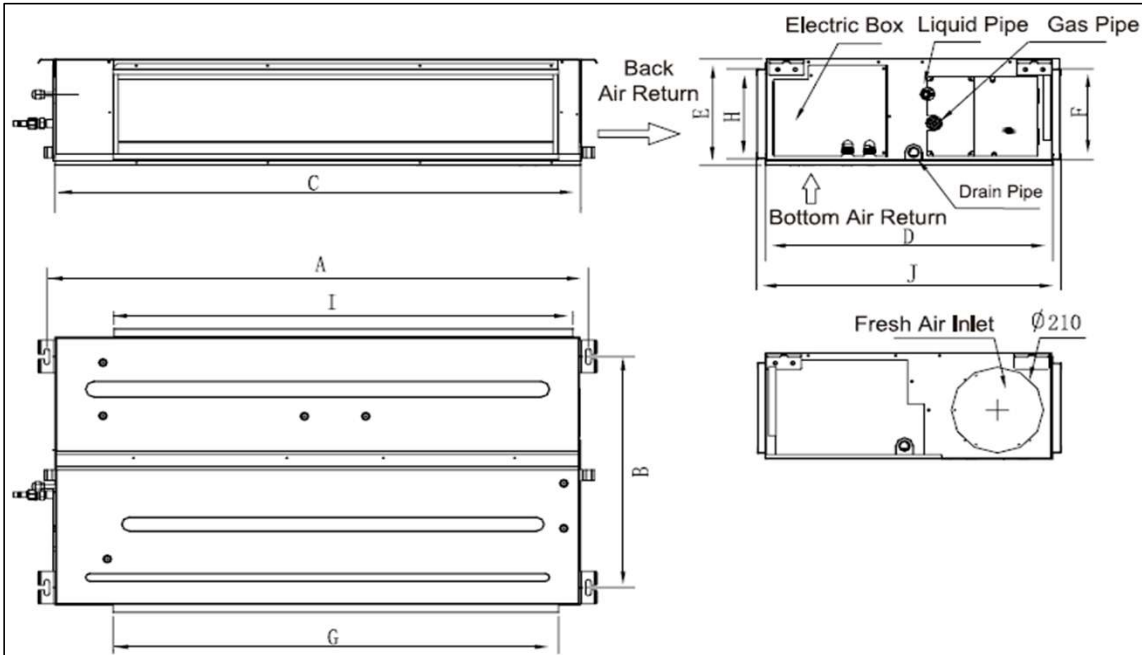

	mm	in
A	1379	54.29
B	565	22.24
C	1340	52.76
D	655	25.79
E	260	10.24
F	207	8.15
G	1153	45.39
H	220	8.66
I	1188	46.77
J	716	28.19

NOTE – Due to Lennox' ongoing commitment to quality, Specifications, Ratings and Dimensions subject to change without notice and without incurring liability. Improper installation, adjustment, alteration, service or maintenance can cause property damage or personal injury. Installation and service must be performed by a qualified installer and servicing agency. ©2014 Lennox Industries Inc.



SUBMITTAL DATA - INDOOR UNIT
VELD048N4U
VRF LOW STATIC FAN COIL EVAPORATOR

Job Name: _____
Location: _____
Schedule No.: _____
System Designation: _____

Engineer: _____
Architect: _____
Date: _____
For: ___ Reference ___ Approval ___ Review ___ Construction

FEATURES

- Auto Addressing installation
- Auto Restart
- Detachable Blower Motor
- Integrated Condensate Pump
- Built-in Electronic Expansion Valve
- LED Display
- Washable Filter
- Water Overflow Protection
- Anti-Freezing Protection

PRODUCT WARRANTY

All covered components - one year limited warranty

SPECIFICATIONS

PERFORMANCE

Cooling Capacity* (Btu/h)		47,768
Heating Capacity* (Btu/h)		54,592
Airflow (CFM)	High	1175
	Medium	885
	Low	677
External Static Pressure	Pa	0 - 50
	in. WC	0 - 0.2
Sound Pressure Level (dBA)	H / M / L	42/40/37

ELECTRICAL DATA

Power Supply (V / Hz / Ph)	220-240/50/1 - 208-230/60/1
MOP (A)	6
Rated Current (A)	Cooling 1.1
	Heating 1.1

DIMENSIONS

Unit Dimensions (in)	Height	10 1/4
	Width	52 3/4
	Depth	25 3/4
Liquid Pipe Connection (in)		3/8
Gas Pipe Connection (in)		5/8
Shipping Weight (lb)		123.5
Net Weight (lb)		103.6

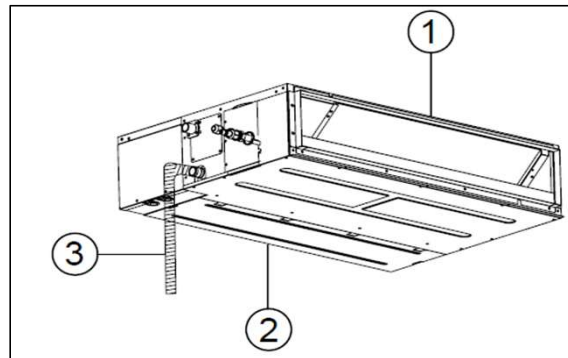
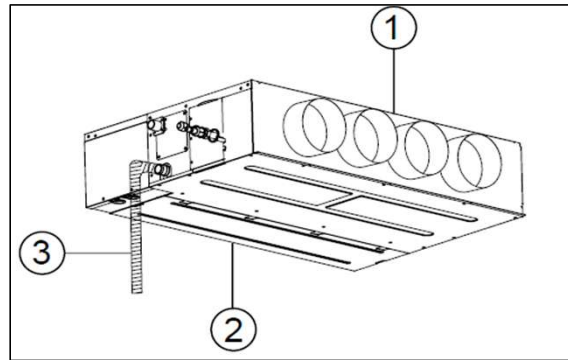

1. Air Outlet
2. Air-Return Opening
3. Drain Pipe

NOTES:

*Cooling and Heating Capacity data is rated at the following conditions:

Cooling: 80 °F DB / 67 °F WB Indoor, 95 °F DB Outdoor

Heating: 70 °F DB Indoor, 47 °F DB

NOTE – Due to Lennox' ongoing commitment to quality, Specifications, Ratings and Dimensions subject to change without notice and without incurring liability. Improper installation, adjustment, alteration, service or maintenance can cause property damage or personal injury. Installation and service must be performed by a qualified installer and servicing agency. ©2014 Lennox Industries Inc.



SUBMITTAL DATA - INDOOR UNIT
VELD048N4U
VRF LOW STATIC FAN COIL EVAPORATOR

DIMENSIONAL DRAWINGS

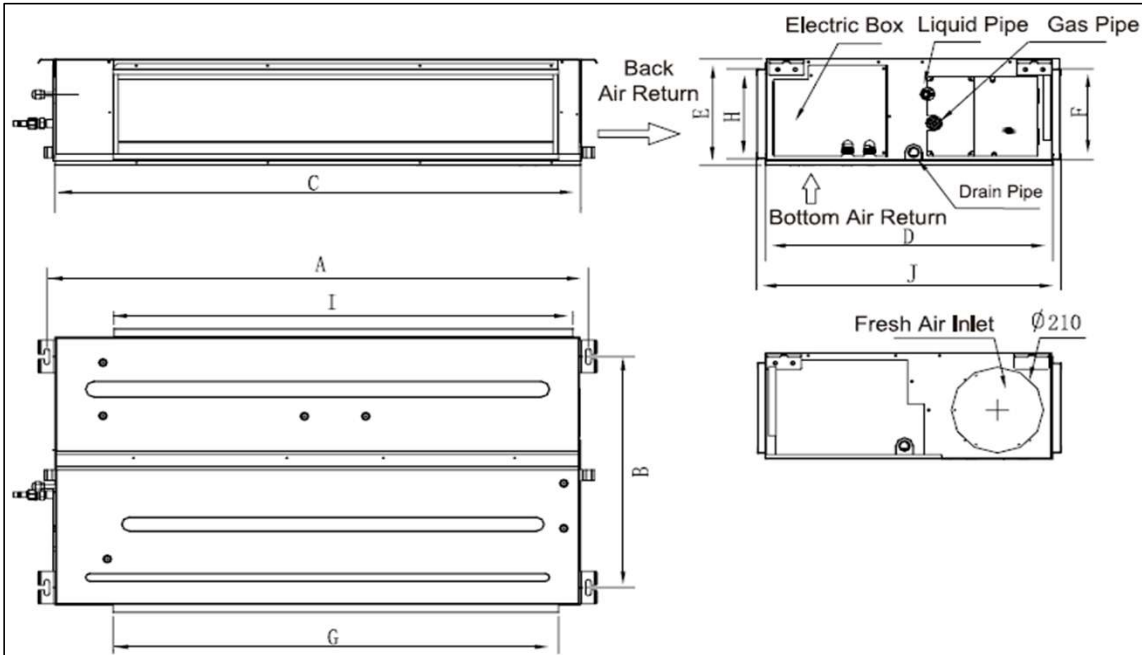

	mm	in
A	1379	54.29
B	565	22.24
C	1340	52.76
D	655	25.79
E	260	10.24
F	207	8.15
G	1153	45.39
H	220	8.66
I	1188	46.77
J	716	28.19

NOTE – Due to Lennox' ongoing commitment to quality, Specifications, Ratings and Dimensions subject to change without notice and without incurring liability. Improper installation, adjustment, alteration, service or maintenance can cause property damage or personal injury. Installation and service must be performed by a qualified installer and servicing agency. ©2014 Lennox Industries Inc.